



HAL
open science

Calibration and monitoring of the GENEPI neutron source for the MUSE IV experiment

J. Vollaire, A. Billebaud, R. Brissot, C. Le Brun, E. Liatard

► **To cite this version:**

J. Vollaire, A. Billebaud, R. Brissot, C. Le Brun, E. Liatard. Calibration and monitoring of the GENEPI neutron source for the MUSE IV experiment. 2003, pp.1-6. in2p3-00013998

HAL Id: in2p3-00013998

<https://in2p3.hal.science/in2p3-00013998v1>

Submitted on 17 Sep 2003

HAL is a multi-disciplinary open access archive for the deposit and dissemination of scientific research documents, whether they are published or not. The documents may come from teaching and research institutions in France or abroad, or from public or private research centers.

L'archive ouverte pluridisciplinaire **HAL**, est destinée au dépôt et à la diffusion de documents scientifiques de niveau recherche, publiés ou non, émanant des établissements d'enseignement et de recherche français ou étrangers, des laboratoires publics ou privés.

Calibration and Monitoring of the GENEPI Neutron Source for the MUSE IV Experiment

J.Vollaire, A.Billebaud, R.Brissot, C.Le Brun, E.Liatard.

*Laboratoire de Physique Subatomique et de Cosmologie, IN2P3-CNRS/UJF/INPG
53 av. des Martyrs, 38026 Grenoble Cedex*

June 6, 2003

In order to characterize the neutron source produced by the GENEPI accelerator with the titanium tritium (TiT) target, an irradiation experiment was performed in January 2003 in the SC0 configuration of MASURCA, with all the rods inserted. During the irradiation, the LPSC acquisition system was used to monitor the number of pulses and the recoil particles produced by the reactions induced by the deuteron beam.

1 Experimental Setup

Five natural nickel foils were symmetrically disposed in the holes of the PSI target holder and a vanadium foil was added to the central nickel foil (figure 1(a)). The target holder was inserted as close as possible to the tritium target of GENEPI in the axial experimental channel of the tube E 19-18 (figure 1(b)).

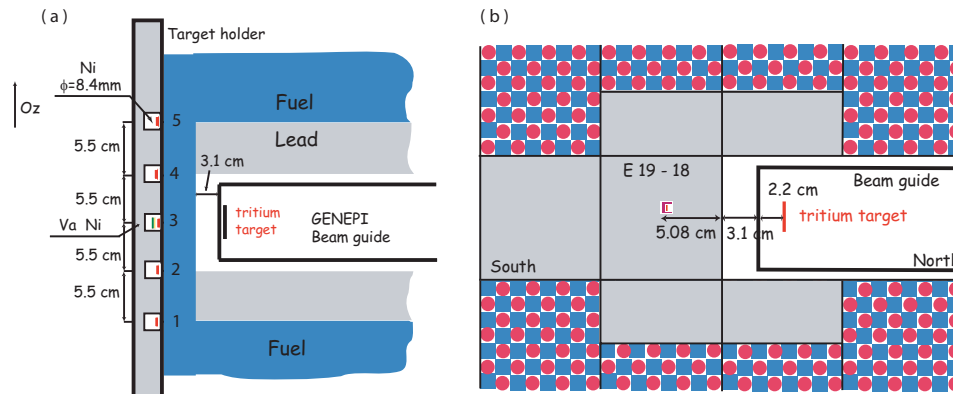

Figure 1: Foil locations. (a): Z-Y cut. (b): X-Y cut in the median plane.

GENEPI was operated at a repetition rate of 4.3 kHz with the deuteron energy set to 220 kV during the 5 hours and 22 minutes of the run. Simultaneously to the foil irradiation, two solid state silicon detectors located in the rear side of the deflection magnet chamber were used to monitor the particles emitted backward and associated to the reactions induced by deuterons impinging the target. This detection allows an indirect monitoring of the source neutrons whose number will be impossible to measure when the experiments are running. The location of these Si detectors allows to measure the alpha-particles created by the $T(d,n)^4\text{He}$ reactions and emitted at 180° in the laboratory system. These charged particles have an energy of 2.56 MeV. Are also detected the 2.52 MeV protons coming from

the $D(d,p)T$ reactions that occur because of the continuous deuteron implantation into the target. Both kinds of particles go back against the flow of deuterons in the beam guide and, because they have roughly the same magnetic rigidity, they are deflected by the magnet to be finally detected together under the same solid angle (see figure 2). The discrimination between protons and alpha-particles, which have almost the same energy, is done by covering one of the two detectors with a thin Al foil ($10\ \mu\text{m}$) which suppresses the alpha-particles in this detector.

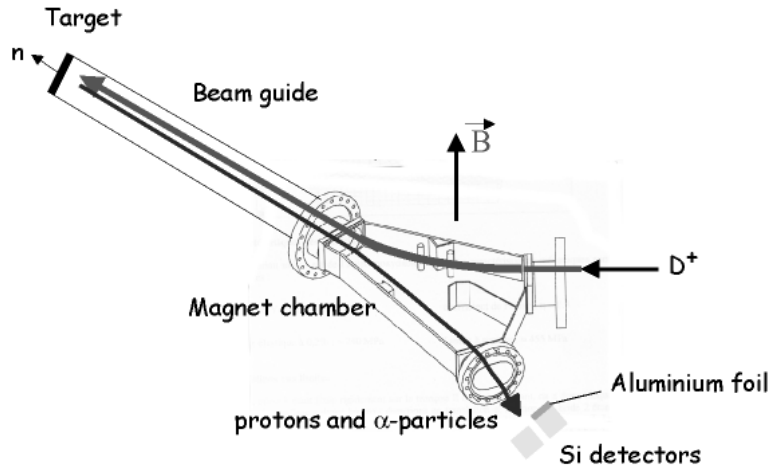

Figure 2: Recoil particle detection in GENEPI magnet chamber.

This detector is usually used to monitor the deuterium target. With the tritium target the proton detection can be useful to estimate the importance of the $D(d,n)^3\text{He}$ reactions, which occur about as often as the $D(d,p)T$ reactions, and therefore allows an estimation of the 2.5 MeV parasitic neutron source.

2 Absolute Calibration

2.1 Method

The foil activation technique was used to measure the absolute number of neutrons produced per pulse. To do so, one vanadium and five nickels foils were used: they were 8.4 mm in diameter and 0.5 mm thick. The four reactions considered are listed in table 1 and their respective cross sections are shown in figure 3.

Foil	Reaction
Nickel	$^{58}\text{Ni}(n,np)^{57}\text{Co}$
Nickel	$^{58}\text{Ni}(n,p)^{58}\text{Co}$
Nickel	$^{58}\text{Ni}(n,2n)^{57}\text{Ni}$
Vanadium	$^{51}\text{Va}(n,\alpha)^{48}\text{Sc}$

Table 1: Reactions of interest for the activation measurement.

The activity of the different radioisotopes produced by the irradiation of the foils was measured in the Low Activity Lab of the LPSC using a low background germanium detector. The number of neutrons per pulse n_0 is deduced from the measured activity using the formula:

$$n_0 = \frac{A_i}{\alpha_i \times f(1 - \exp(-\lambda_i t_{irrad}))} \quad (1)$$

where A_i is the measured activity of the radioisotope i , α_i is the number of reactions occurring in the foil per source neutron, f is the repetition rate of the GENEPI source, λ_i is the decay constant of radioisotope i and t_{irrad} the irradiation time.

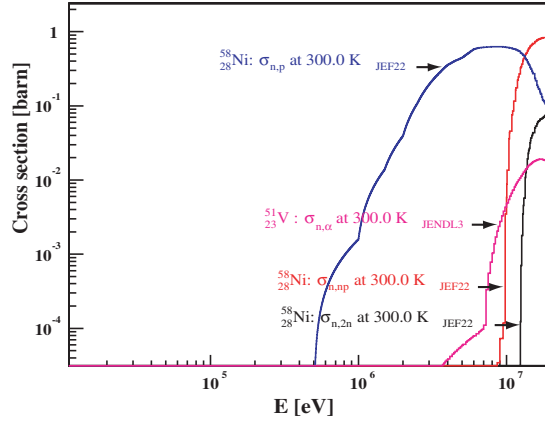

Figure 3: Cross sections of the reactions listed in table 1.

The number of reactions in the foil per source neutron α_i is deduced from a MCNP calculation made with a precise description of the geometrical configuration based on the figure 1 and the assumed shape of the deuteron beam (ellipsoidal shape, $\langle \Phi \rangle \sim 2$ cm), and using nuclear data bases cross sections for the different reactions. The calculation pointed out the importance of the neutron emission location, specially for reactions characterized by high energy thresholds when foils are very close to the tritium target. Figure 4(a) shows the dependence of the measured activity with respect to the foil location for some reactions and figure 4(b) gives the number of neutron per pulse deduced from the relation (1) and these measurements.

The fact that the number of neutrons per pulse does not depend on the position of the foil indicates that the neutron transport is well simulated by the MCNP calculation. On the other hand, there is an important discrepancy on the value of n_0 depending on the reaction considered. The cross section of the $^{58}\text{Ni}(n,2n)^{57}\text{Ni}$ reaction leads to a reaction rate in the foils which seems too important and thus the calculated value of n_0 is lower than for the others reactions. This discrepancy may come from the important variation of these cross section in the energy range of the source neutrons (around 15 MeV) whose distribution depends strongly on the transport calculation.

2.2 Result

Finally, the chosen value for the neutron production is the average of the ones obtained with the $^{58}\text{Ni}(n,p)^{58}\text{Co}$ reactions and the $^{51}\text{Va}(n,\alpha)^{48}\text{Sc}$ reactions and is equal to $3.3 \pm 0.3 \times 10^6$ neutrons per

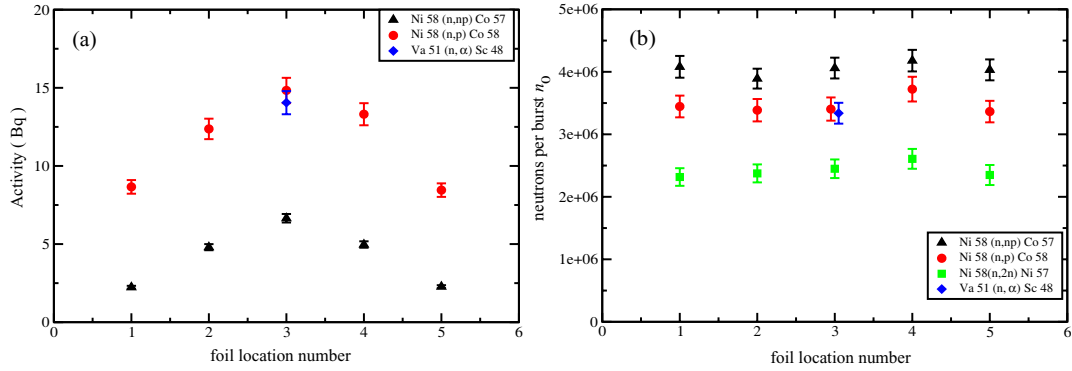

Figure 4: (a): Measured activities.(b): Number of neutrons per pulse.

pulse for the present TiT target. This value corresponds to the target activity on the 22nd of January 2003 (initial activity 10 Ci at loading in November 2002) under standard and optimized deuteron beam intensity (40 mA peak current - oscilloscope measurement).

2.3 Parasitic 2.5 MeV Neutron Source

The number of protons detected during the irradiation run, corresponding to reactions occurring on the deuterium implanted into the target, can give an estimation of the 2.5 MeV neutron production (as this reaction occurs about as often as the one producing neutrons). If we assume that the transmission of protons and alpha-particles is roughly the same (we will see that this assumption holds in section 4), we can estimate the fraction of this parasitic source to 0.17% of the total number of source neutrons, which will have no significant effect on the total energy spectrum of the source.

3 Online Monitoring of the Source

3.1 Source Intensity Monitoring

The intensity of the 14 MeV source along the MUSE IV experimental programme will be monitored using the detection of alpha-particles: to do so, the number of alpha-particles detected must be correlated to the number of neutrons produced by the source. Consequently the monitoring detectors were recorded during the foil irradiation. The amplitude distribution measured by the silicon detector is shown in figure 5. Peaks corresponding to the simultaneous detection of one or several alpha-particles or protons - leading to pile-up events - are clearly seen.

Thus the total number of alphas particles detected is easily calculated taking into account the multiplicity of each peak ($N_{\alpha}^{Tot} = \sum_{i=1}^8 i n_i$). The number of alpha-particles detected per pulse of deuterium ions is found equal to 0.83. Finally, for the experimental conditions described in section 2 the ratio of alpha-particles counted in the silicon detector per neutron produced by the TiT target is equal to $\frac{N_{\alpha}}{n_0} = 2.44 \pm 0.24 \times 10^{-7}$. This value will be used for future online monitoring of the source, without forgetting that it depends on GENEPI tuning.

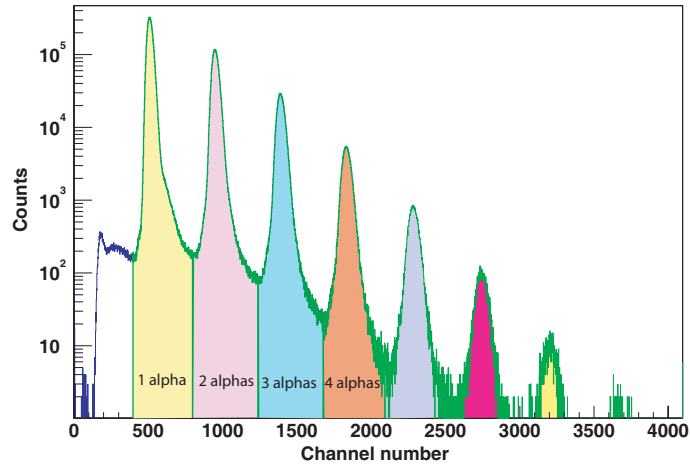

Figure 5: Multiplicity distribution of recoil particles.

3.2 Time Shape of the Neutron Pulse

The time shape of the neutron pulse is obtained from the time distribution of the alpha particles in the silicon detector. Figure 6(a) shows on a logarithmic scale the spectrum for all particles impinging the silicon detector. Two main peaks are seen. The small one on the left side, corresponding to the shorter time of flight of the particles corresponds to the detection of protons coming from (d,D) parasitic reactions occurring in the magnet chamber (and due to deuteron implantation in the magnet walls). The main peak at longer times of flight is due to events occurring in the target. The distribution shown in figure 6(b) was obtained by selecting the two alphas events (see figure 5) in order to avoid parasitic events. A Gaussian fit performed on this time distribution gives a value of $\sigma = 168$ ns which corresponds to a FWHM = 400 ns for a standard GENEPI pulse.

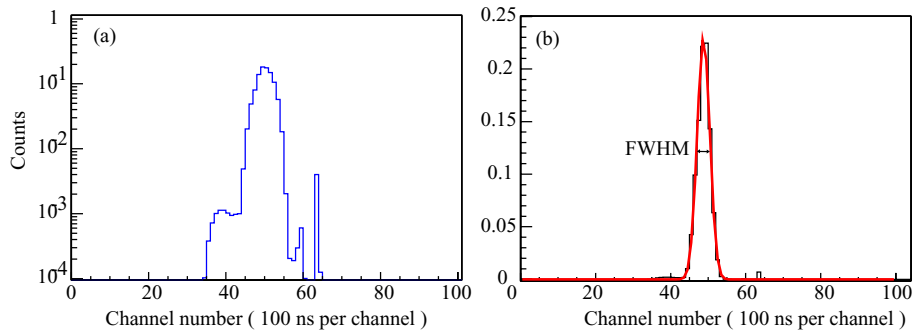

Figure 6: Time spectrum of the particle emitted backward.

3.3 Amplitude Distribution of the Deuteron Pulse Intensity

The distribution of the integral value of the deuteron current pulse shown in figure 7 gives a reliable idea of the fluctuation of the beam intensity of pulses during a five hours run. The small peak on the left side corresponds to the two beam losses which occurred during the run. The distribution follows a gaussian shape characterized by a relative dispersion $\frac{\Delta I}{I} = 0.08$ which confirms the good stability of

the machine and the reproducibility of the pulse.

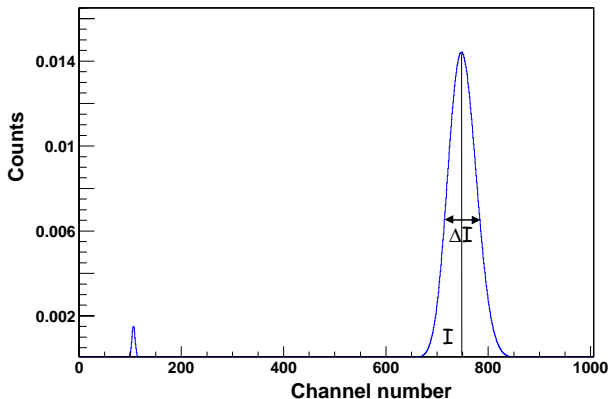

Figure 7: Amplitude distribution of the integrated deuteron pulse current.

4 Neutron Production and Monitoring with the Deuterium Target

The first titanium deuterium target (TiD) installed in GENEPI in November 2000 (1.2 mg of deuterium) was also the subject of a calibration experiment performed on the 5th of April 2001. The experiment consisted in the irradiation of 5 nickel foils in a way very similar to that described above. The result of the absolute calibration of the source was $3.0 \pm 0.3 \times 10^4$ neutrons per pulse, for a 60 mA peak current (oscilloscope measurement). The source monitoring, done in this case by the two detectors (both of them receiving only protons), gave $5.75 \pm 0.05 \times 10^{-3}$ proton detected per pulse, leading to $1.92 \pm 0.20 \times 10^{-7}$ proton per source neutron. We can notice that this transmission factor is rather close to the one of alpha-particles, as expected, apart from the focalization conditions which are optimized but might have changed during the 2 years of operation.

5 Conclusion

From this irradiation experiment, the source characteristics were obtained with a good accuracy. The absolute value of the neutron source was measured but also the relation between the online monitoring and the source. To follow more precisely the source evolution in time, another irradiation will be performed before the target removal scheduled in June. This future irradiation will be a good way to check that this method is relevant for the monitoring of the neutron production.

6 Acknowledgments

The authors are very grateful to C.Destouches for his help during the running of these experiments, and would like to thank the MASURCA and GENEPI operating teams, and especially M.Fruneau, P.Chaussonnet and J.-M.Laurens.