



HAL
open science

Technical report on positron source project WA103 at CERN

R. Kirsch

► **To cite this version:**

| R. Kirsch. Technical report on positron source project WA103 at CERN. 2000, pp.50. in2p3-00013505

HAL Id: in2p3-00013505

<https://in2p3.hal.science/in2p3-00013505v1>

Submitted on 2 Nov 2000

HAL is a multi-disciplinary open access archive for the deposit and dissemination of scientific research documents, whether they are published or not. The documents may come from teaching and research institutions in France or abroad, or from public or private research centers.

L'archive ouverte pluridisciplinaire **HAL**, est destinée au dépôt et à la diffusion de documents scientifiques de niveau recherche, publiés ou non, émanant des établissements d'enseignement et de recherche français ou étrangers, des laboratoires publics ou privés.



Institut de P hysique N ucléaire de L yon

Collisions A tomiques dans les S olides

IN2P3 - CNRS UNIVERSITE CLAUDE BERNARD-LYON 1
43 Boulevard du 11 Novembre 1918 F 69622 VILLEURBANNE Cedex

[© Copyright CNRS](#)

Technical Report

on

Positron source project - WA103 at CERN

Documents, Images, CAO models and specifications
Lyon contribution - R.K. 03/11/2000 - V03.2

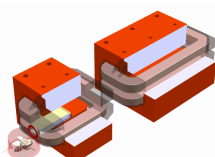

[3D view](#)

(1200k) needs silicon Graphics Cosmo Player or equivalent plug in.



[Back](#)

[Drift chamber](#)

Build at BINP tested at LAL

[Goniometer](#)

**Hardware LAL, software
IPNL**

[Magnets](#)

**CERN MBPS (short) and
MBPL (long).**

[Assembling](#)

Validation IPNL.

[X5A Beam line](#)

CERN documentation [X5.](#)

Software

As defined by LAL - IPNL

W Crystal

Target holder, X & γ
Diffraction, Models.

Photon detectors

Preshower and calorimeter.

Tracking

Track reconstruction,
simulations and results.

Collaboration

Involved institutes.

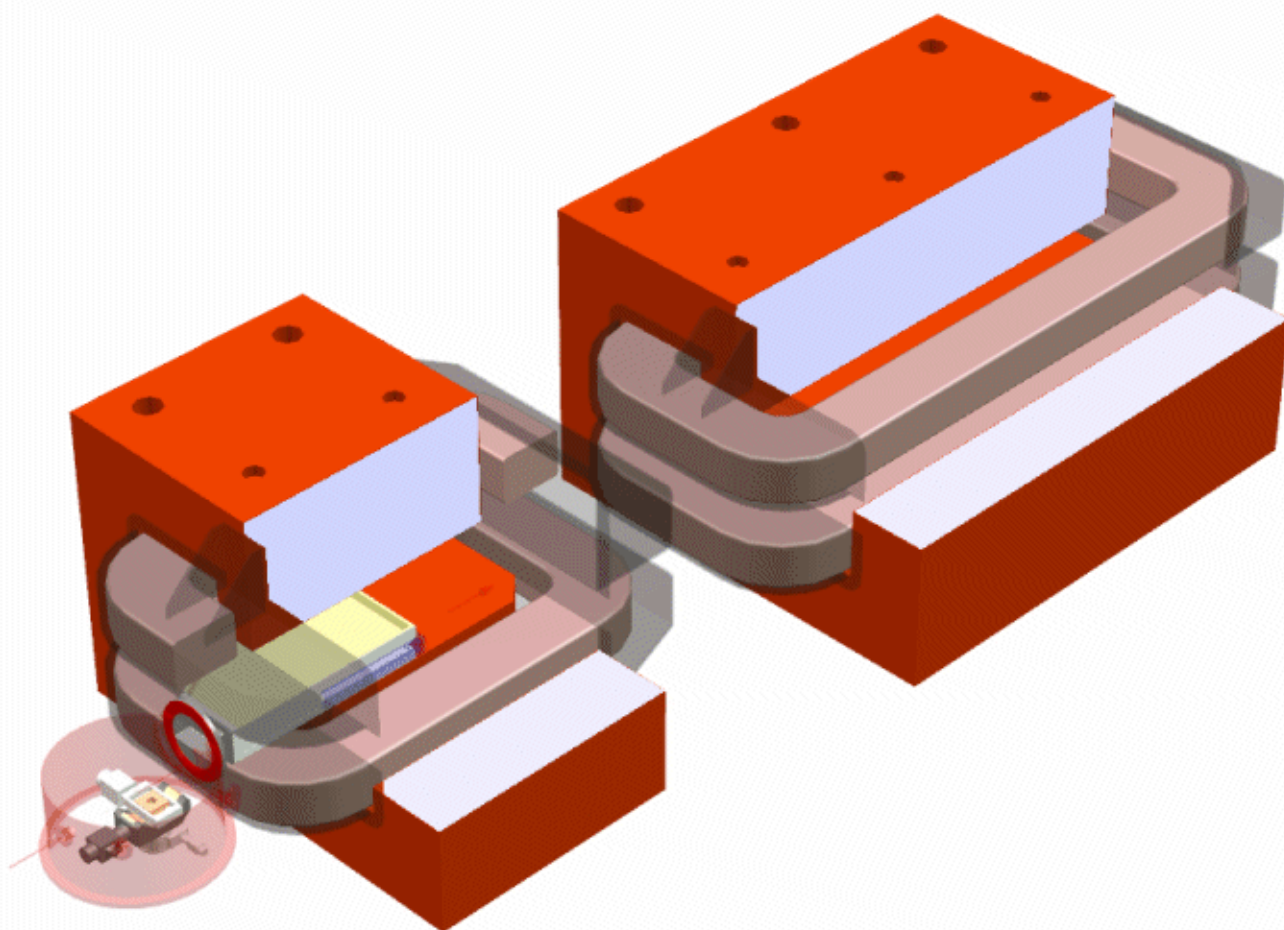

**Orsay - Novosibirsk - Lyon - Stuttgart - Kharkov - Tomsk
Collaboration August 2000**

R. Chehab, R. Cizeron, C. Sylvia, (LAL-IN2P3, Orsay, France)
V. Baier, K. Beloborodov, S. Burdin, A. Bukin, A. Drozdetsky, M. Dubrovin, V. Druzhinin,
T. Dimova, V. Golubev, S. Serednyakov, V. Shary (BINP, Novosibirsk, Russia)
X. Artru, M. Chevallier, D. Dauvergne, R. Kirsch, Ph. Lattes, J-C. Poizat, J. Remillieux, (IPNL-IN2P3, Villeurbanne, France)
A. Jejcic (LMD-University, Paris, France)
P. Keppler, J. Major (Max Planck Institut, Stuttgart, Germany)
L. Gatignon (CERN, Geneva, Switzerland)
G. Bocek, V. Kulibaba, N. Maslov (KIPT, Kharkov, Ukraine)
A. Bogdanov, A. Potylitsin, I. Vnukov (NPI-TPU, Tomsk, Russia)

Copyright notice

© Copyright CNRS - Institut de Physique Nucléaire de Lyon - 2000.

All rights reserved. This document is produced by Robert Kirsch in the frame of his work at CNRS. The document, the CD, the programmes, images and files here in contained are copyrighted works of CNRS. Reproduction in whole or in part of this document or its content, without the express written permission of the copyright holders is prohibited. Information in this document and attached files is subject to change without notice.

Tous droits réservés. Ce document est une réalisation de Robert Kirsch dans le cadre de son travail. Les droits d'auteur de ce document, du CD, des programmes, des images et des fichiers qu'il contient appartiennent au CNRS. IL est interdit de reproduire tout ou partie de ce document sans le consentement préalable et écrit du propriétaire des droits d'auteur. Certaines informations contenues dans ce document sont susceptibles d'être modifiées sans préavis.

® Registered trademarks : CNRS acknowledges that some of the names referred to are registered trademarks. ® Marques déposées : Certains noms cités dans ce document constituent des marques déposées.

Robert KIRSCH - Collisions Atomiques
Phone : (33) 04 72 44 84 47 Bâtiment 214, VdG
Fax : (33) 04 72 43 12 43
[Mail](mailto:kirsch@ipnl.in2p3.fr) : kirsch@ipnl.in2p3.fr





Institut de P hysique N ucléaire de L yon

Collisions A tomiques dans les S olides

IN2P3 - CNRS UNIVERSITE CLAUDE BERNARD-LYON 1
43 Boulevard du 11 Novembre 1918 F 69622 VILLEURBANNE Cedex
[© Copyright CNRS](#)

Positron source drift chamber - WA103 CERN experiment

Documents, Images, CAO models and postscript files

R.K. Lyon

v1 08/06/99

v2 03/03/00 wires in D.C., D.C. in magnet

v3 08/06/00 D.C. and wires in measured field

 [back](#)

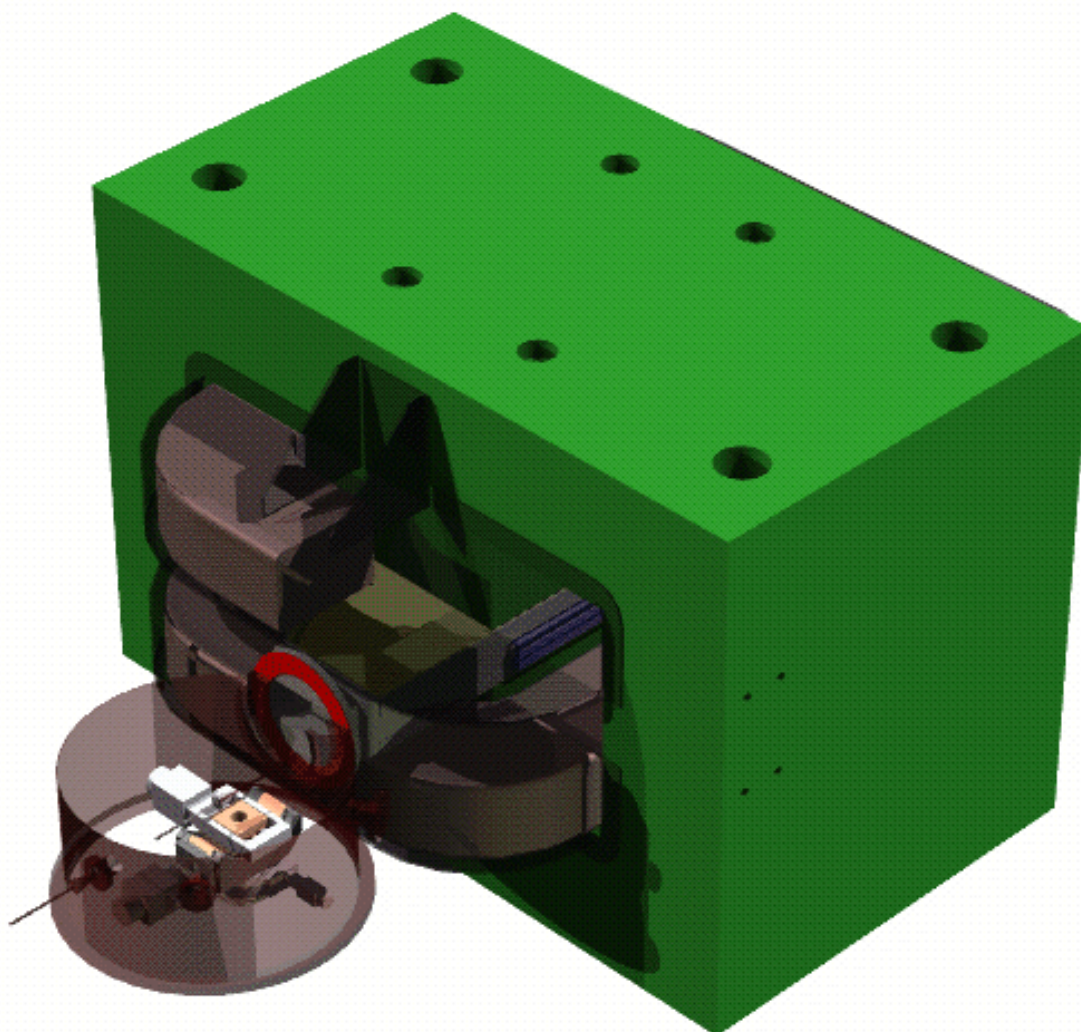

Drift chamber

- Photos from Novosibirsk : D.C. entrance & Model R.K..
- Photos from Novosibirsk : D.C. exit & Model R.K..
- Adaptor between D.C and goniometer vessel.

Designed & produced by LAL.

- Wires in D.C. and MBPS magnet
- Field measurement at CERN

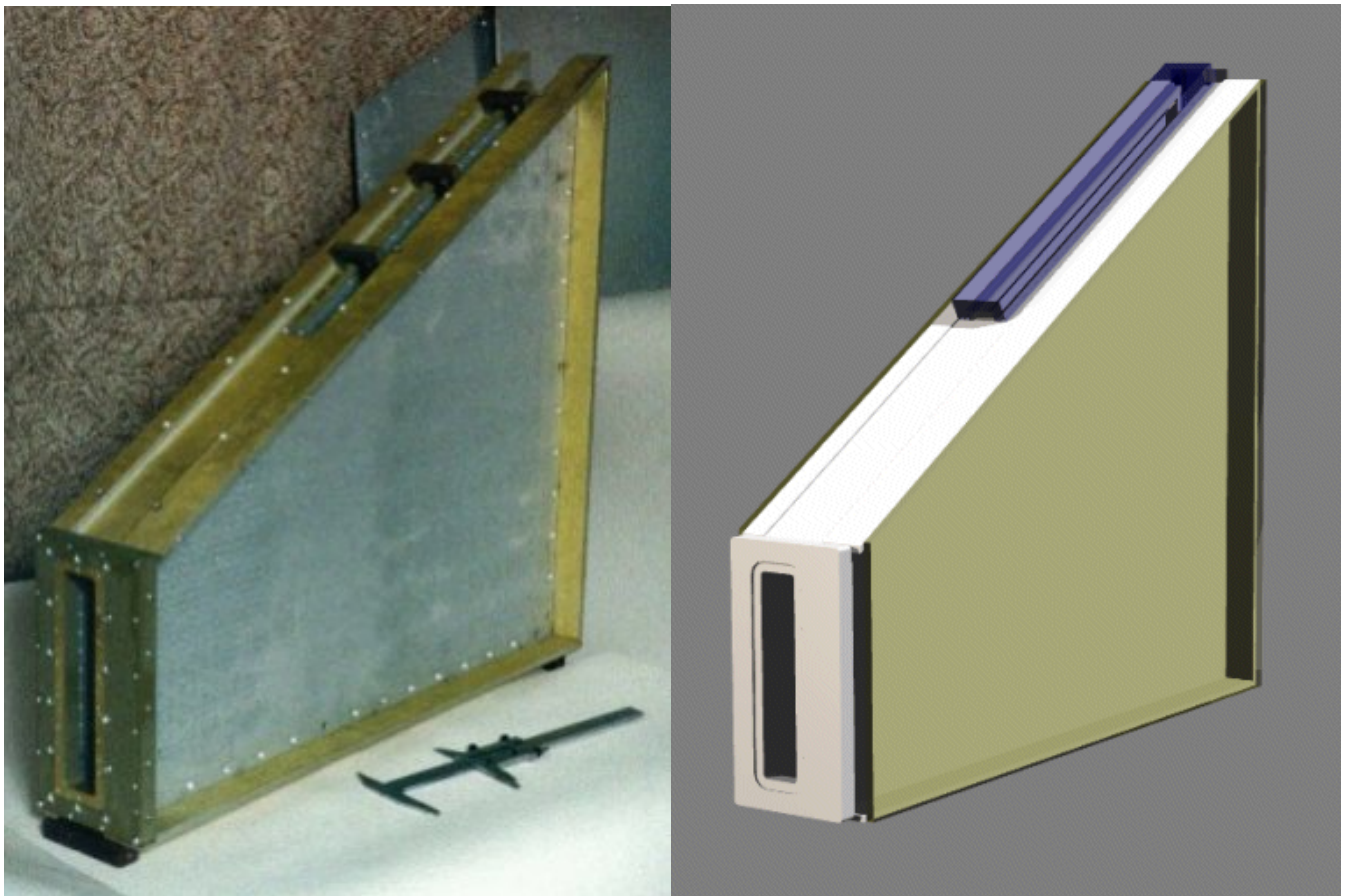

Novosibirsk Photo D.C. entrance & Lyon Model

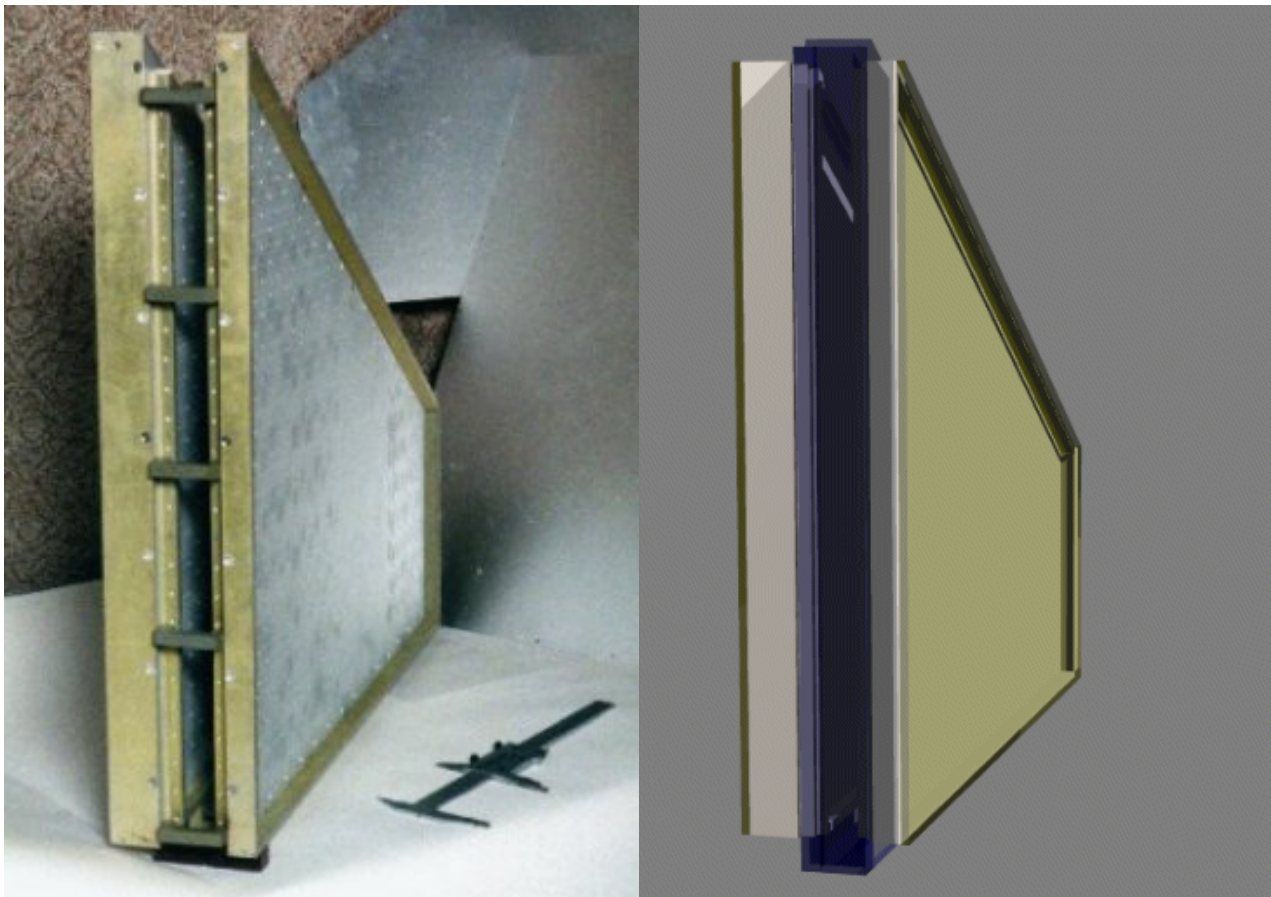

Novosibirsk Photo D.C. exit & Lyon Model

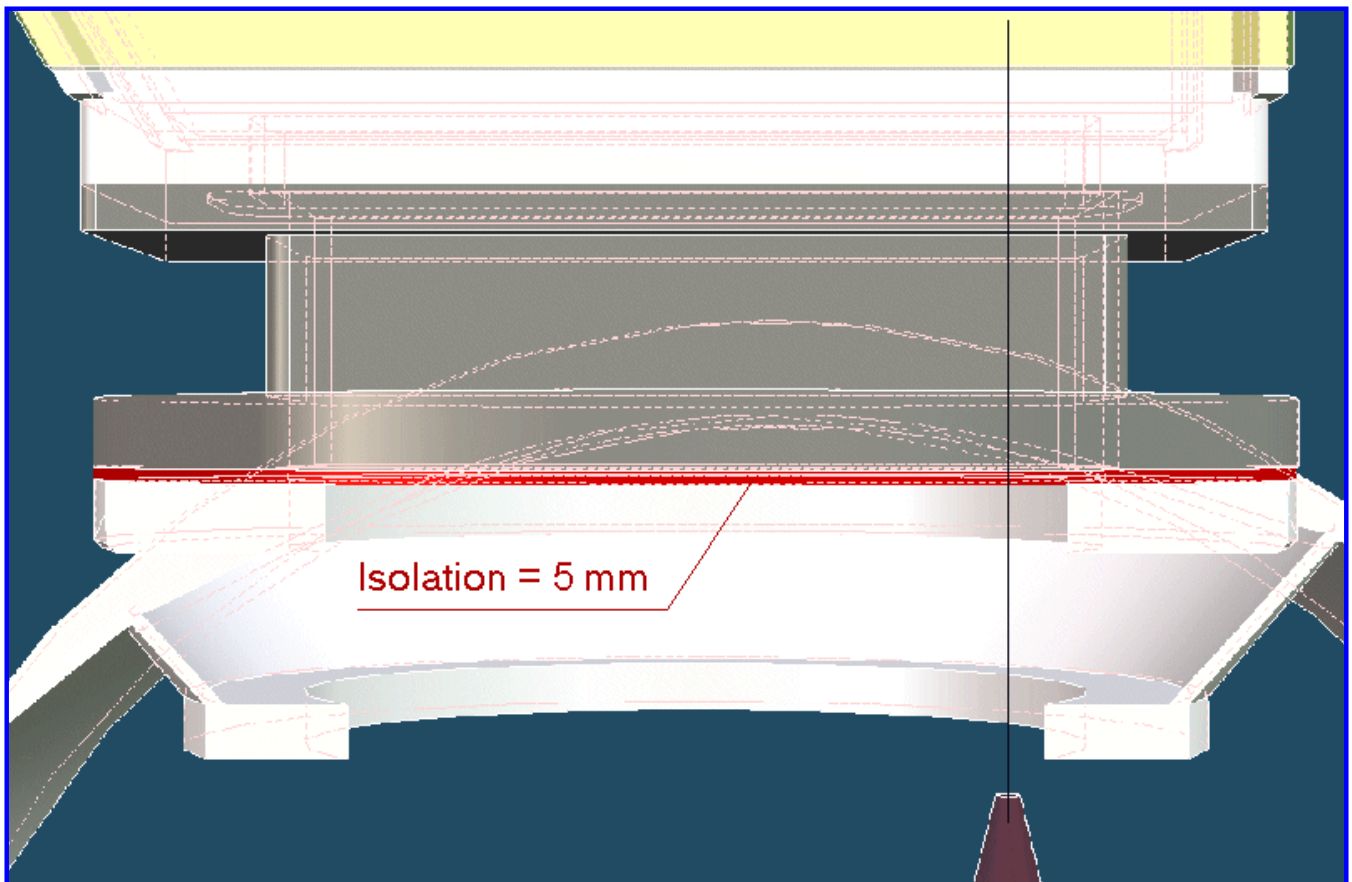

D.C entrance connection to goniometer vessel.
(Adaptor designed & produced by LAL)

Wires in Drift Chamber

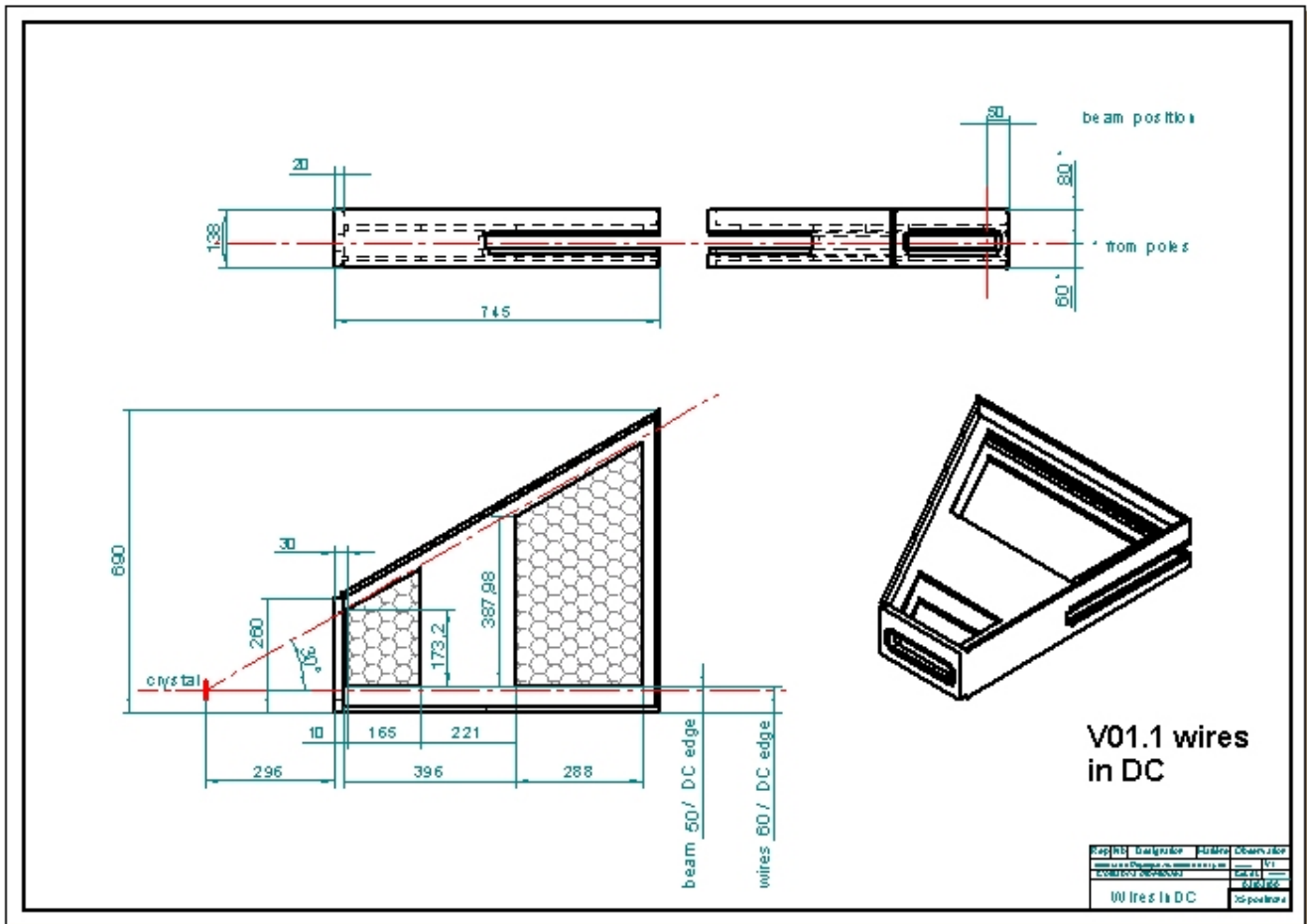

The positions of the wires in the drift chamber : ([X5wiresInDCv01.ps](#))

Drift Chamber in magnet MBPS

Warning : The position of the D.C. in the magnet poles is defined in the next drawing. The field leakage zone on the next drawing is approximate. It nevertheless shows that a large amount of wires will be in a non homogeneous field (see field measurement below).

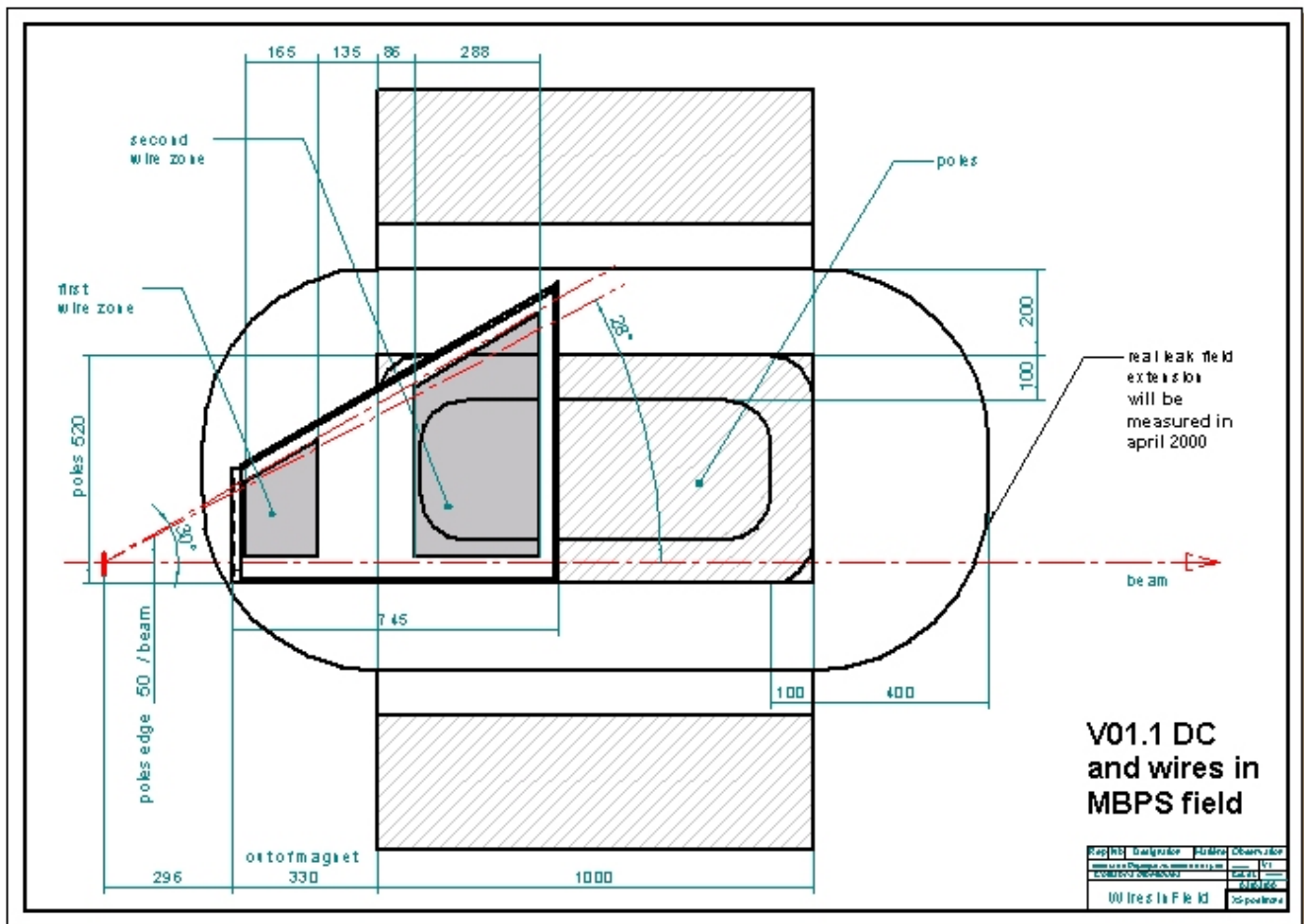

The D.C. in the magnet poles : ([X5wiresInFieldv01.ps](#))

Field measurement

The plots below show vertical (y component) field value along the beam path in MBPS for 0.4 and 0.1 Tesla. The negative values on the plots are the longitudinal values (z components) of the field. The positions of the DC two wire zones A (in the poles) and B (out of poles) show that the wires outside the poles are in a variable field :

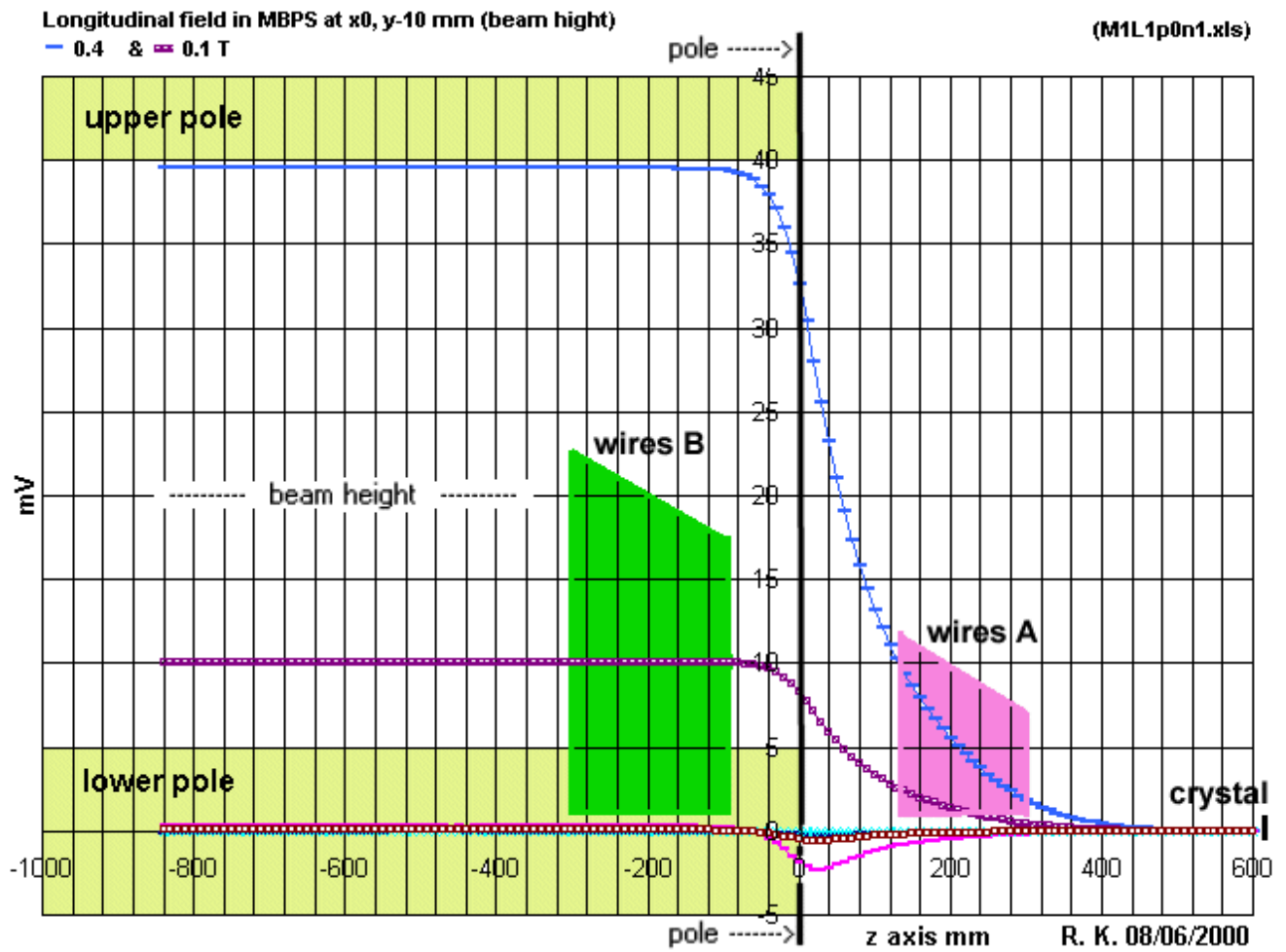

Field map measured at CERN by Wilfried Flegel and Felix Bergsma (plot R.K. [postscript](#))

Institut de P hysique N ucléaire de L yon

Collisions A tomiques dans les S olides

IN2P3 - CNRS UNIVERSITE CLAUDE BERNARD-LYON 1
43 Boulevard du 11 Novembre 1918 F 69622 VILLEURBANNE Cedex

[© Copyright CNRS](#)

Positron source goniometer - WA103 CERN experiment

Documents, Images, CAO models and postscript files

R.K. Lyon 08/06/99

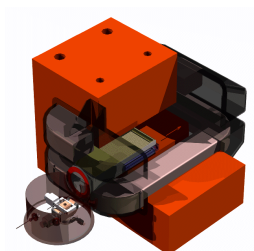

[3D](#) view



Goniometer

Target movements :

1. Rotation (vertical axis perpendicular to the beam)
2. Tilt (horizontal axis perpendicular to the beam)
3. Lateral translation (target change or beam spot change)

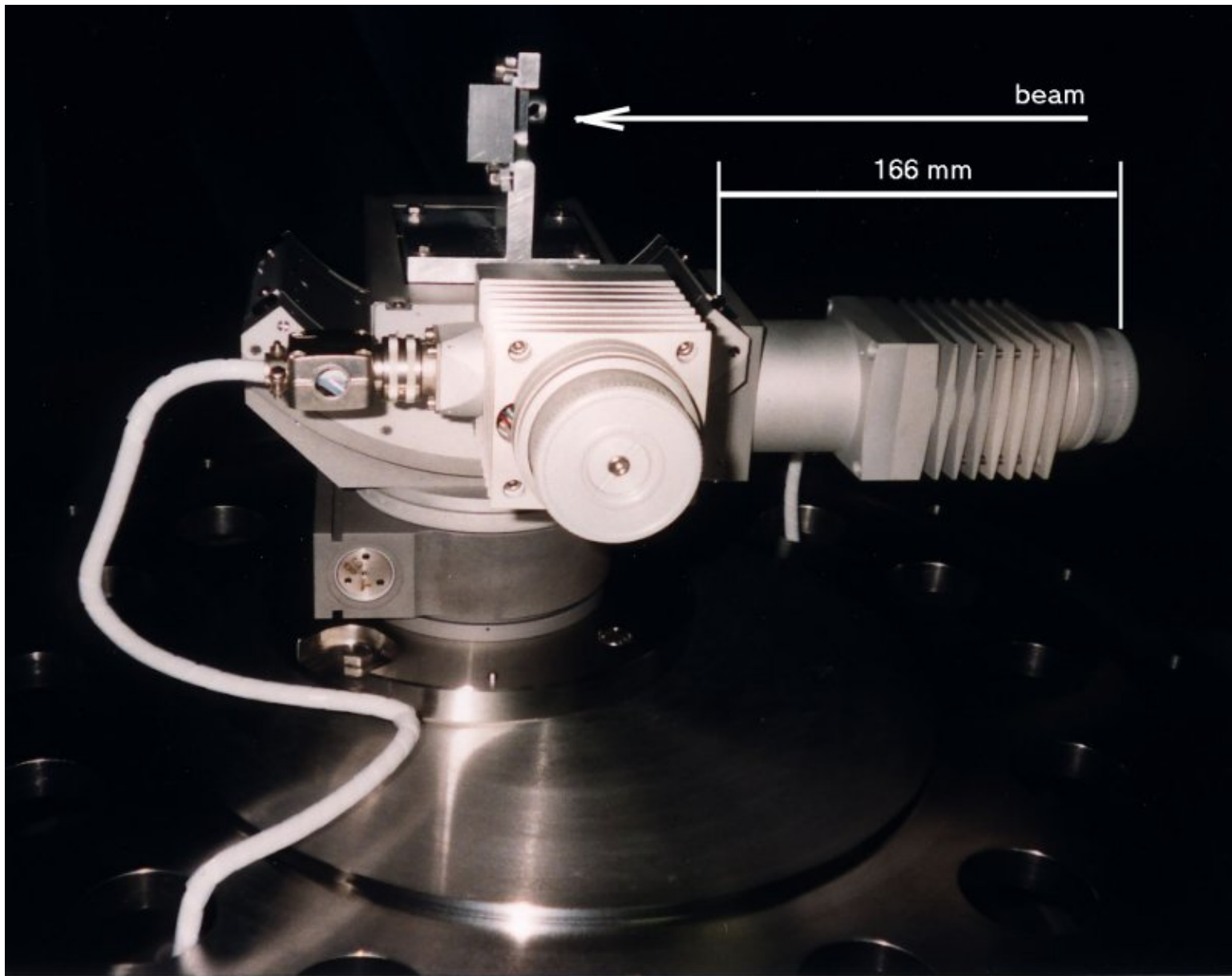

Side photograph [3D view](#)

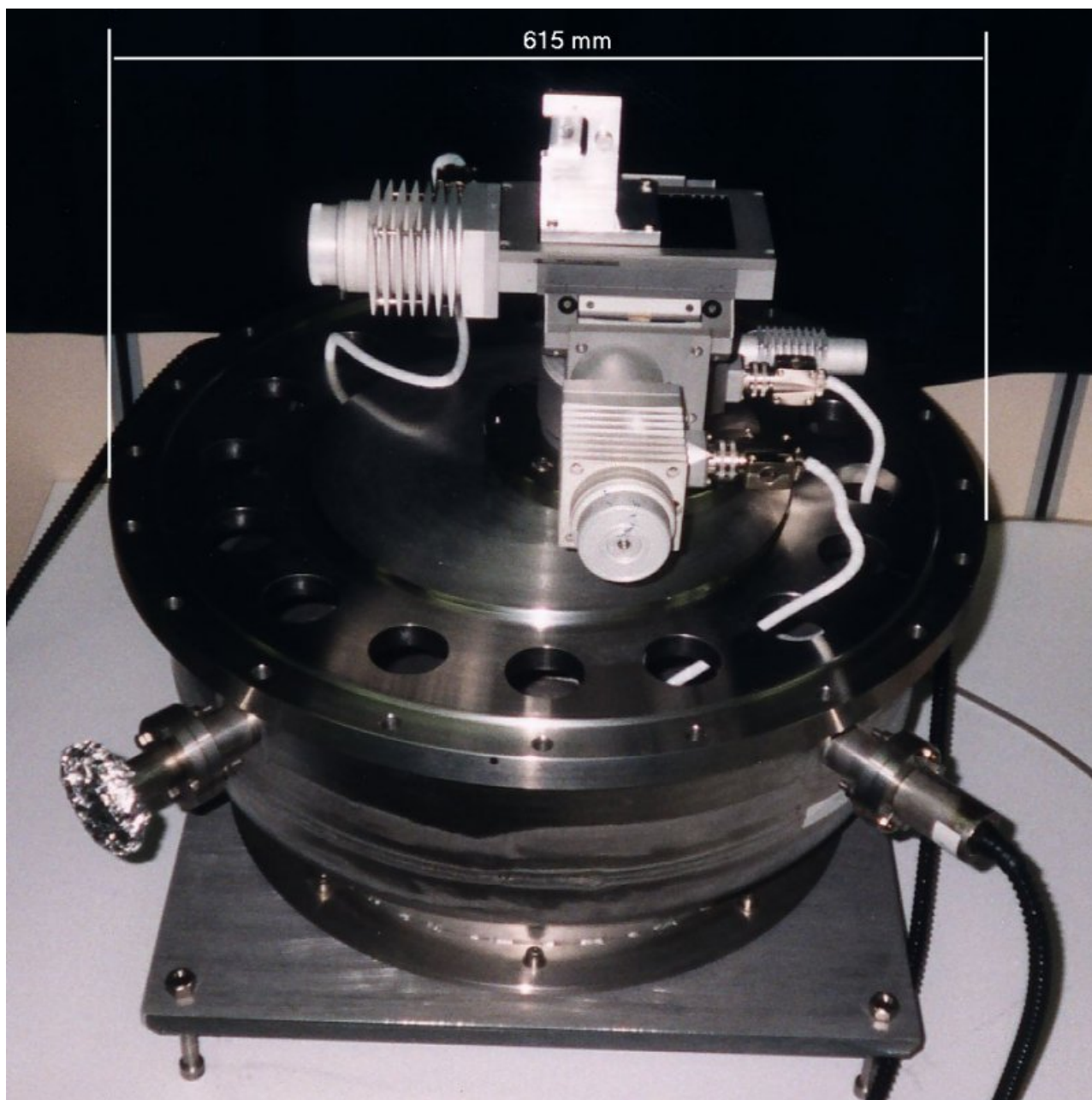

Front photograph as seen by the beam

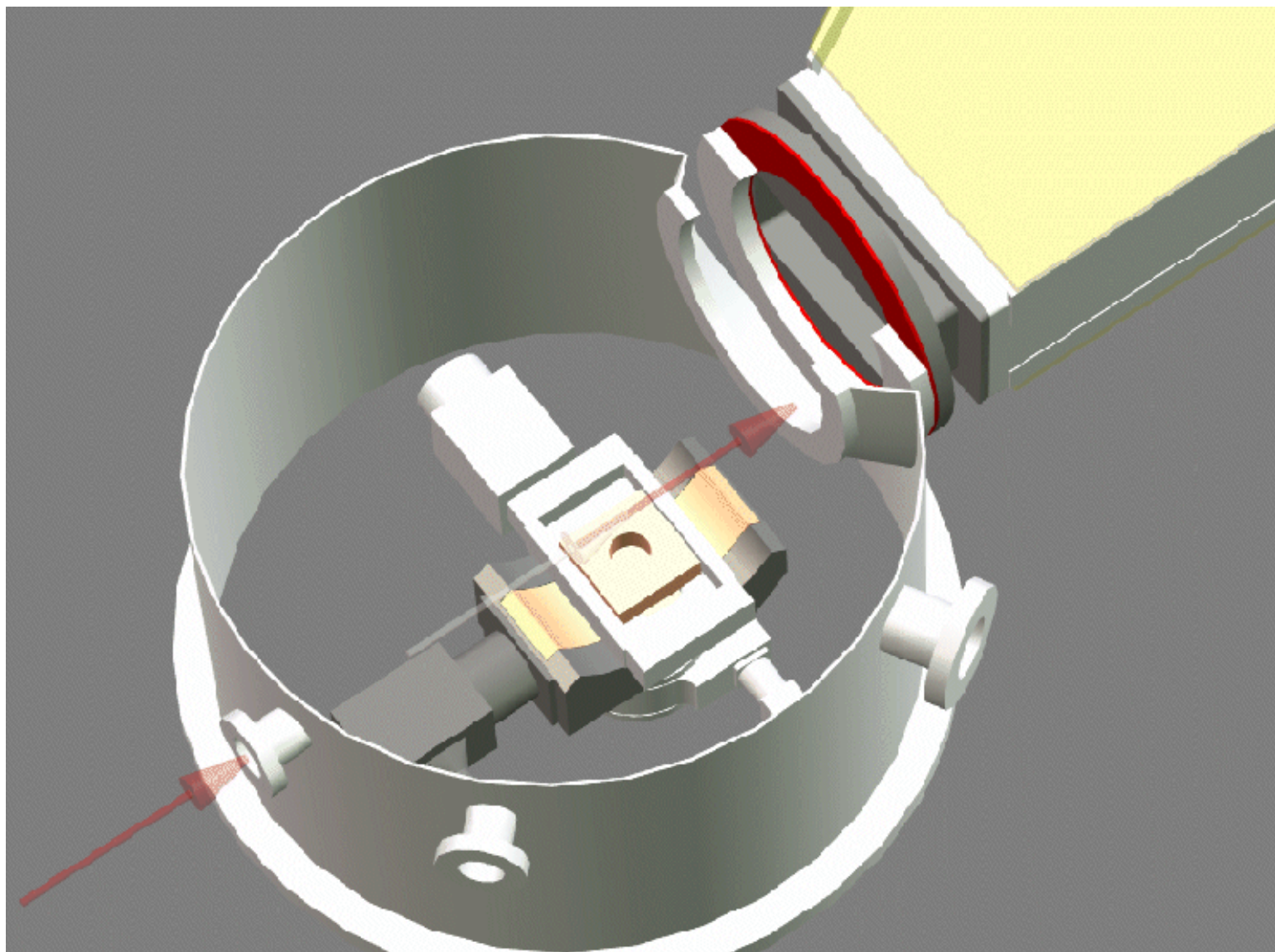

View into the goniometer chamber with beam path. [3D](#) view

Institut de Physique Nucléaire de Lyon

Collisions Atomiques dans les Solides

IN2P3 - CNRS UNIVERSITE CLAUDE BERNARD-LYON 1
43 Boulevard du 11 Novembre 1918 F 69622 VILLEURBANNE Cedex

[© Copyright CNRS](#)

Positron source magnets - WA103 CERN experiment

Documents, Images, CAO models and postscript files

R.K. Lyon 08/06/2000 - V2

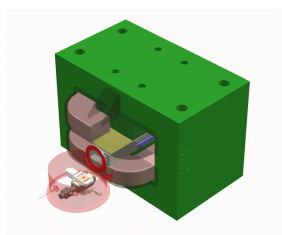

[3D view \(900k\)](#)



Magnets

Specification	First Spectrometer magnet	Second Sweeping magnet
Type	MBPS	MBPL
Length	1000	2000
Width	1740	1740
Height with nominal gap	1160	1160
Pole width	520	520
Pole gap hight nominal (adjustable)	140 (110, 170, 200)	140 (110, 170, 200)
Nominal current $A = I_N$	675	
Flux density with I_N	1.64 Wb/m ²	
Weight	15 tonnes	
Source	CPS users handbook	

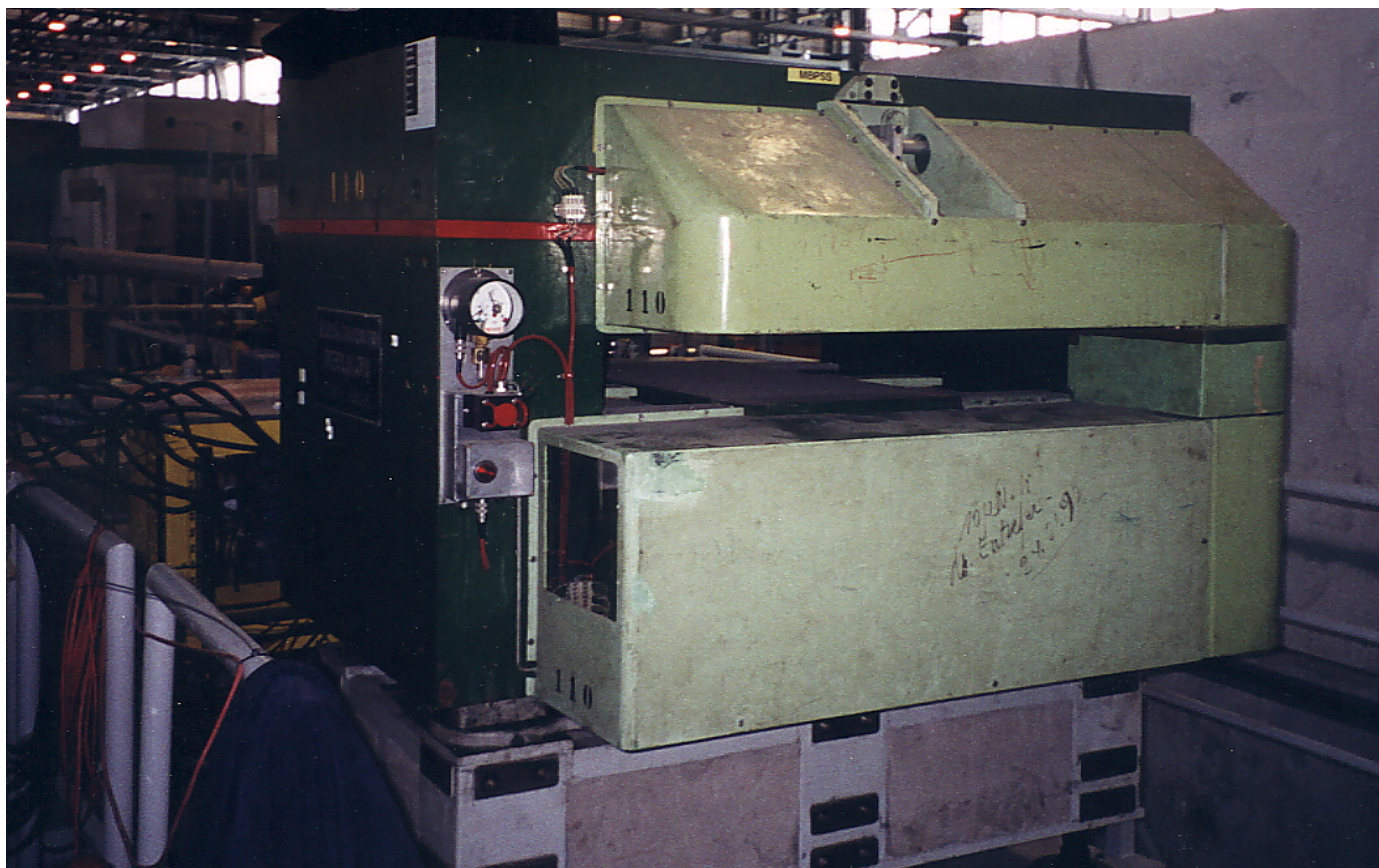

MBPS entry, photographed at CERN (R.K.)





MBPS exit, photographed at CERN (R.K.)

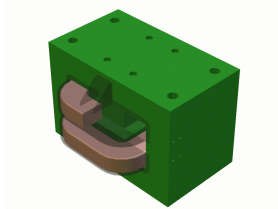

MBPS[3D](#) (300k)

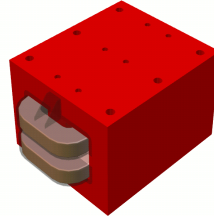

MBPL [3D](#) (300k)

- Magnet coil protection
 - = 330 mm on beam entrance (short side)
 - 380 mm on beam exit (long side)

- Lateral steady field width limit
 - = 400 mm from beam line to left steady field limit

- Drift Chamber and magnetic field :
 - Entrance part **"no" field** length = 330 mm
 - from entrance of D.C. to pole entrance edge
 - Left side corner **out of pole** length = 162 mm
 - from left pole edge to left D.C. corner
 - See on figure below, when clicked

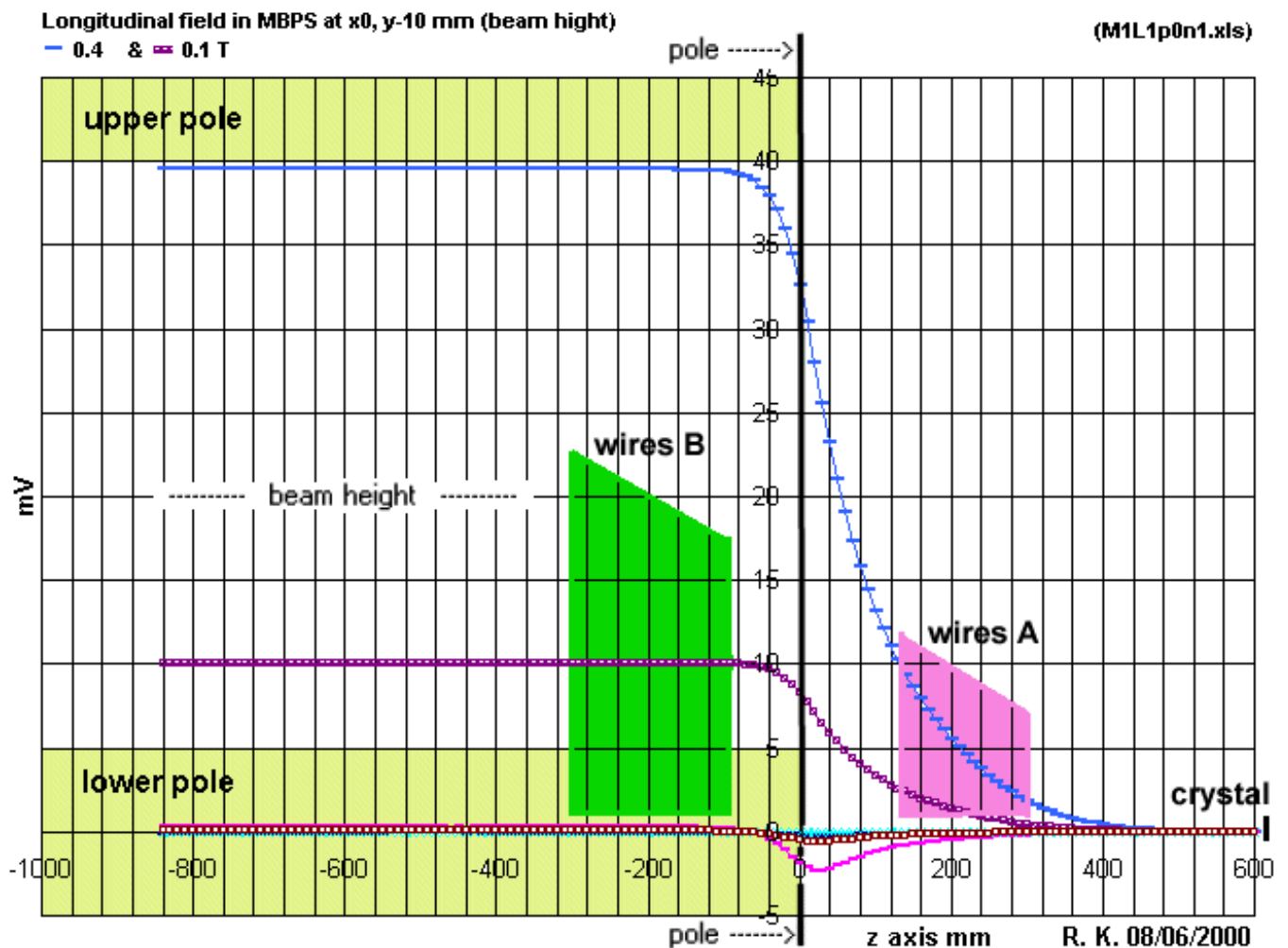

[postscript](#) figure

Pole width = 520 mm. For a gap of 140 mm, the longitudinal field decreases from 100% to 80% over about 80 mm before reaching the pole edge.

The zone A wires of D.C. chamber, out of the poles, are in a high gradient leak field reaching about 1/4 of the nominal field.

Institut de P hysique N ucléaire de L yon

Collisions A tomiques dans les S olides

IN2P3 - CNRS UNIVERSITE CLAUDE BERNARD-LYON 1
43 Boulevard du 11 Novembre 1918 F 69622 VILLEURBANNE Cedex
[© Copyright CNRS](#)

Positron source assembling - WA103 CERN experiment

Documents, Images, CAO models and postscript files
R.K. Lyon

v1 08/06/99

v2 03/03/00 X5 Beatch, area setup, DC position in MBPS update

v2.1 19/04/00 obsolete images removed



Assembling and setup

- Drift Chamber (D.C.) in magnet general view.
- X5 area experiment [setup](#)
- Adaptor between D.C and goniometer vessel.

Designed & produced by LAL.

- Side view of goniometer in chamber & D.C. in magnet.
- View into the goniometer chamber with beam path.
- [Postscript](#) drawings of D.C. setup (for printing)

with main dimensions :

- [Top](#) view
- [Side](#) view
- [Back](#) view
- [Iso](#) view

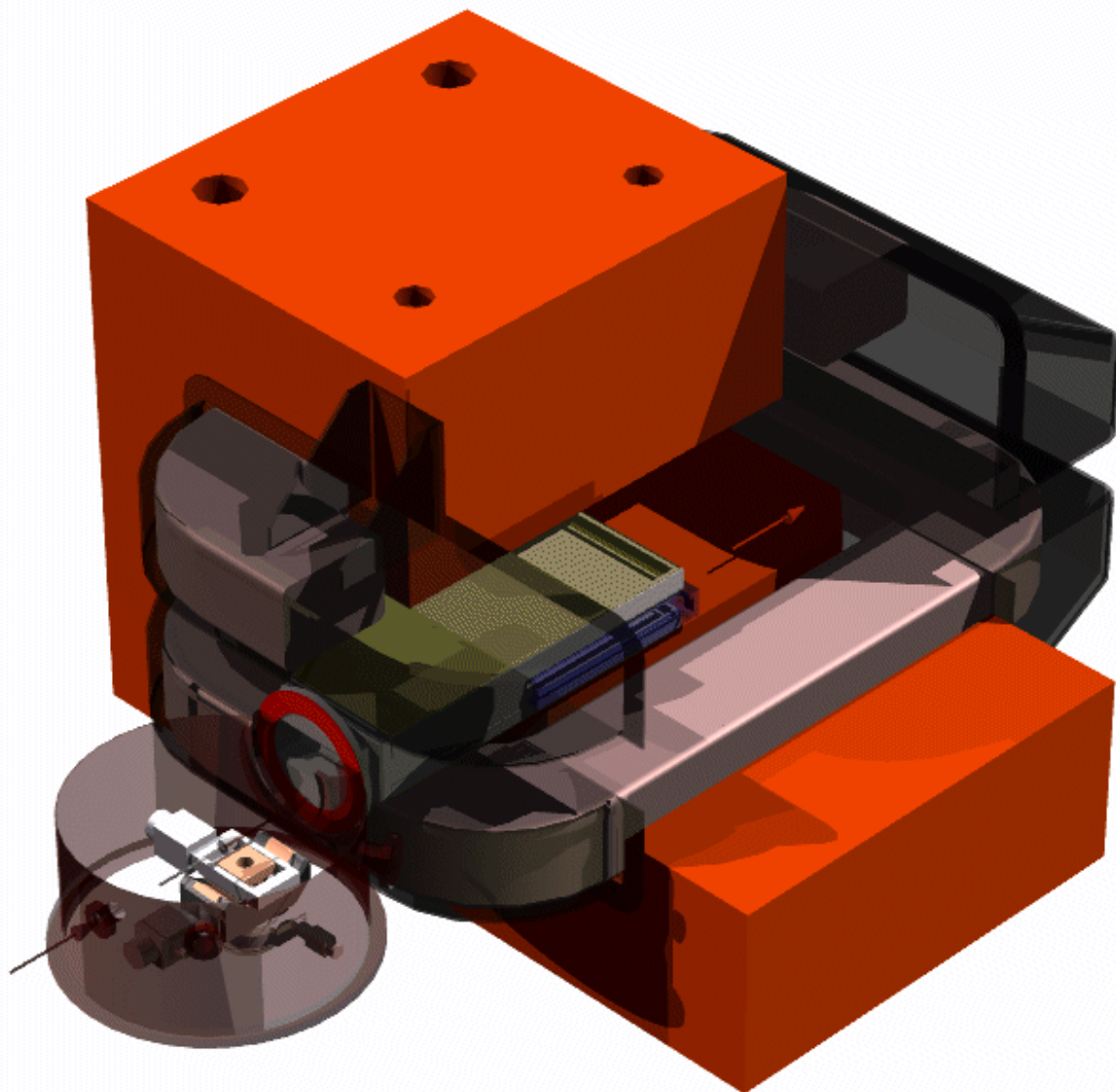

Drift Chamber (D.C.) assembled general view.

[3D](#) VRML view (900k). [With](#) sweeping magnet [3D](#) (1200k).

X5 area setup

[Beatch](#) file describing X5

X5 longitudinal Layout
position size and comments

C1A1 -14750 not yet exactly defined ± 100

entrance of X5 0 end of concrete blocks

C2A2 1400 16150 from C1A1 to C2A2

SC = 1614 4 XDET frames supporting scintillators C2A2

IC = 330 from entrance to center of goniometer vessel
X = 30 from center of goniometer vessel to crystal position
sub total = 1974

crystal position 1974

OutX = 231 from crystal position to exit of goniometer vessel
DCC = 65 coupling with Drift Chamber (DC)
sub total = 296

DC entrance 2270

DCoutF = 330 DC out of mag. field = coil of MBPS at mag.entrance

start of field 2600 DCinF = 415 DC in magnetic field, gap = 140 mm

EP = 585 empty longitudinal pole space in MBPS

end of field 3600 EC1 = 380 Out coil of MBPS at magnet exit

sub total = 1710 MBPS total length

end of MBPS 3980 MBPS pole gap = 140

FS1 = 290 free passage between magnets MBPS and MBPL

start of MBPL 4270 MBPL pole gap = 140

IC2 = 330 In coil of MBPL at magnet entrance (supposed value)

start of field 4600 1000 from MBPS end of field

M2 = 2000 MBPL magnetic nominal field length, gap = 140 mm

end of field 6600

OC2 = 380 Out coil of MBPL at magnet exit (supposed value)
sub total = 2710 MBPS total length (supposed value)

end of MBPL 6980

FS2 = 4994 free space from MBPL magnet to preshower

preshower start 11974 10000 from crystal 5374 / MBPL field

PS = 20 preshower 110x110 length estimation

preshower end 11994

FS3 = 130 free space from preshower to gamma calorimeter

calorimeter start 12124 150 mm from preshower entrance

GC = 450 gamma calorimeter length

calorimeter end 12574

photomultipl. end 13574 CPM = 1000 light guide and photomultiplier estimation

sub total = 1600 preshower and calorimeter

FS = 3996 free passage from photomultiplier to concrete blocks

exit of X5 17570

=====

X5 transverse layout of the 1 meter MBPS

Note : center of pole gap is NOT CENTERED on nominal beam line :

pole width = 520 pole gap = 140 (see also X5drawingMagnetLayout.ps)

Compared to the beam, center has :

vertical offset : center = 10 mm UP / beam (poles horizontal, see also X5drawingLayoutV02.ps)

lateral offset : center = 210 mm LEFT / beam (viewed with beam in the back and pole width = 520)

=====

all other elements are centered on beam line

=====

The above informations are also in the postscript file : [X5xlsLayoutV02.ps](#)

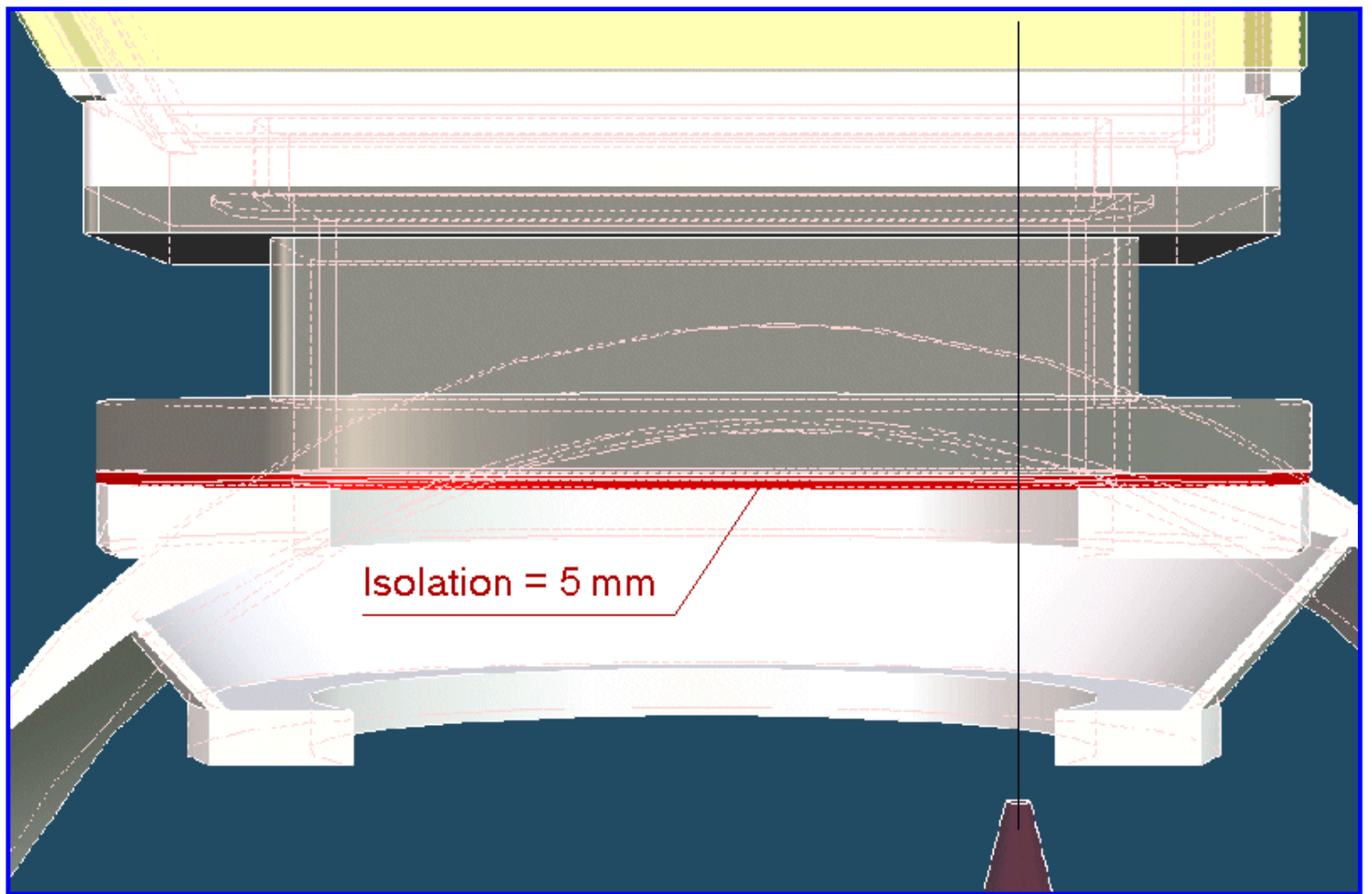

**Adaptor between D.C and goniometer vessel.
Designed & produced by LAL**

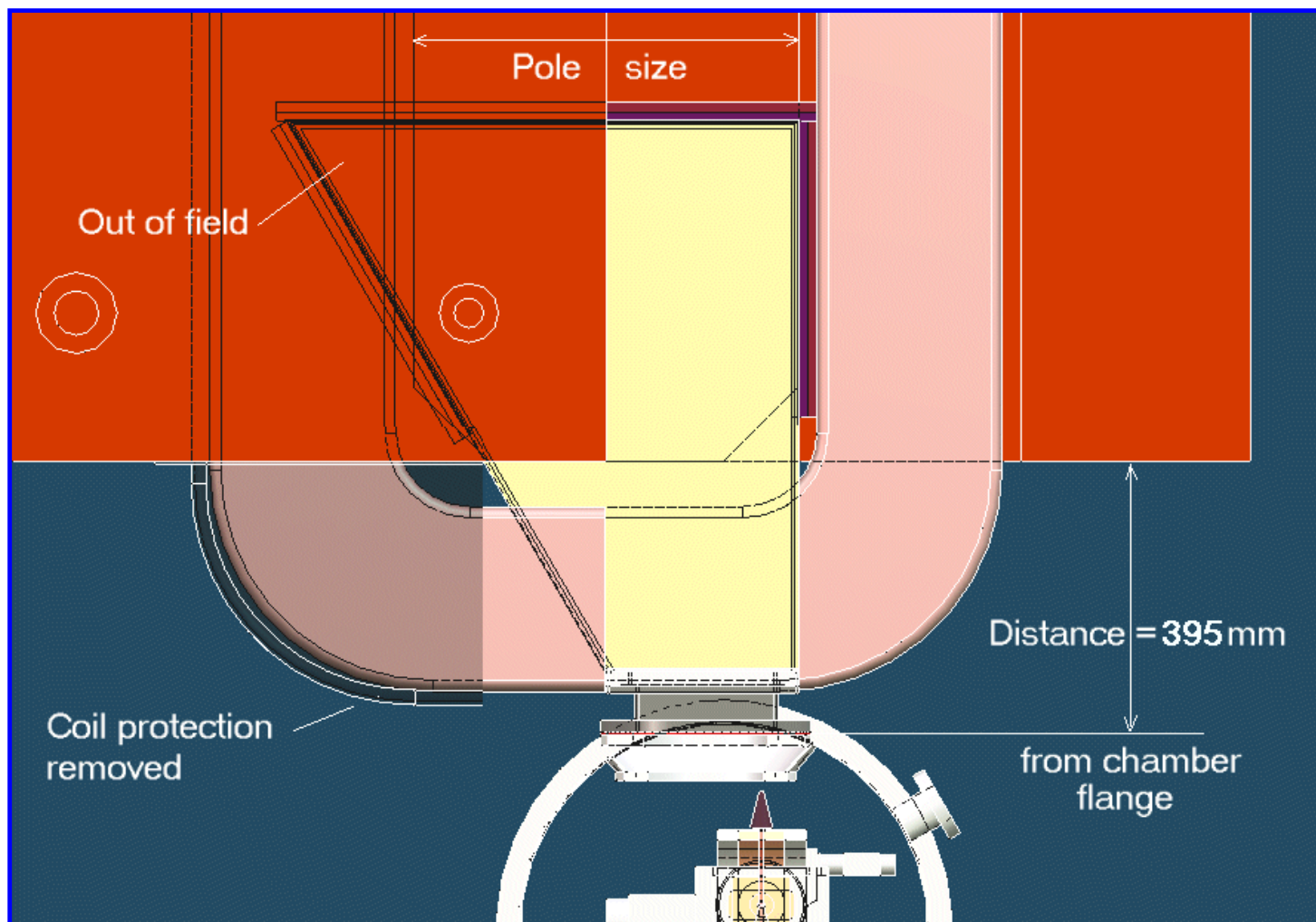

D.C. in magnet and goniometer chamber :
notice the entrance part out of field
the upper left part out of field due to the pole width

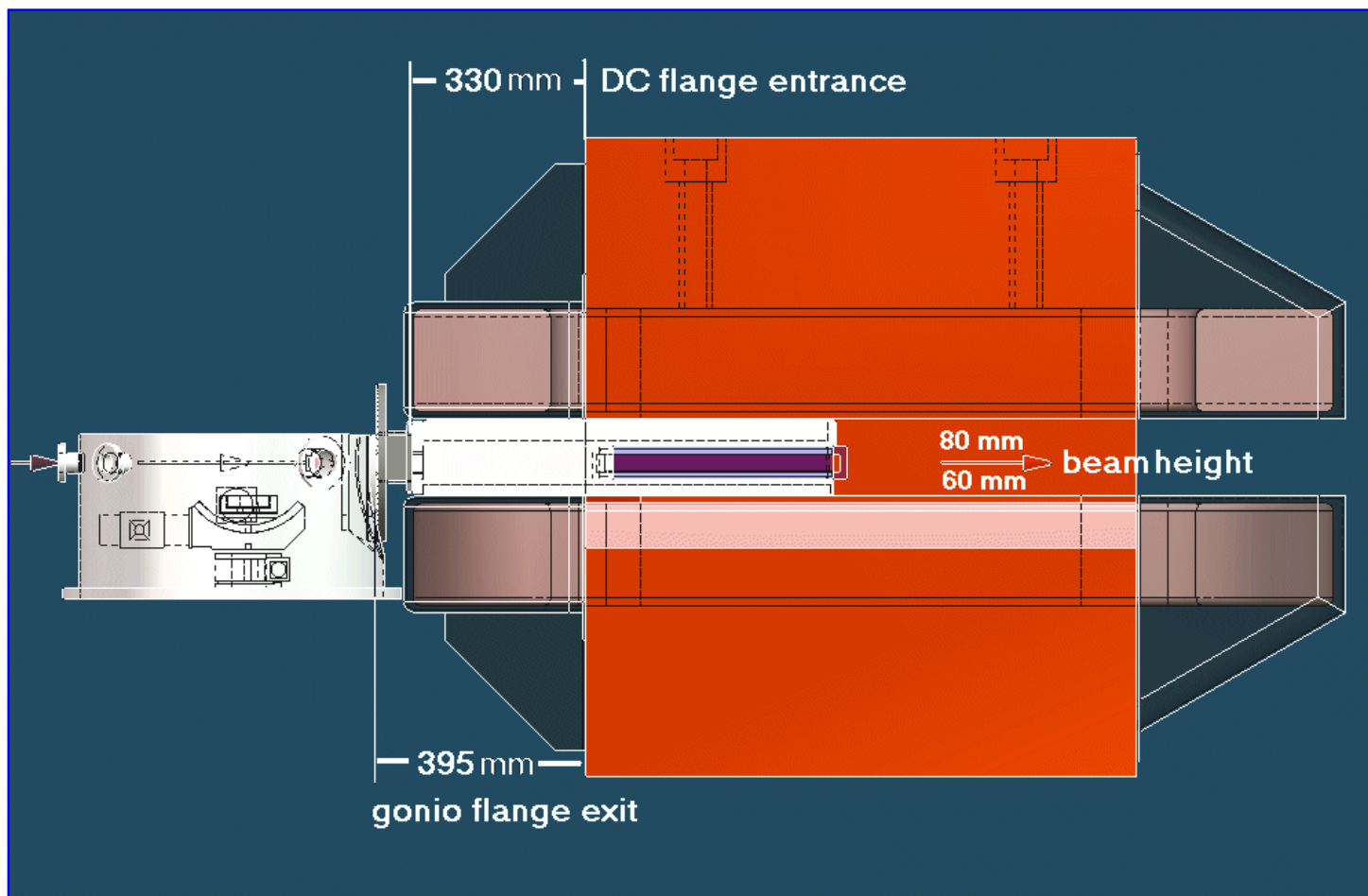

Side view of goniometer in chamber & D.C. in magnet.

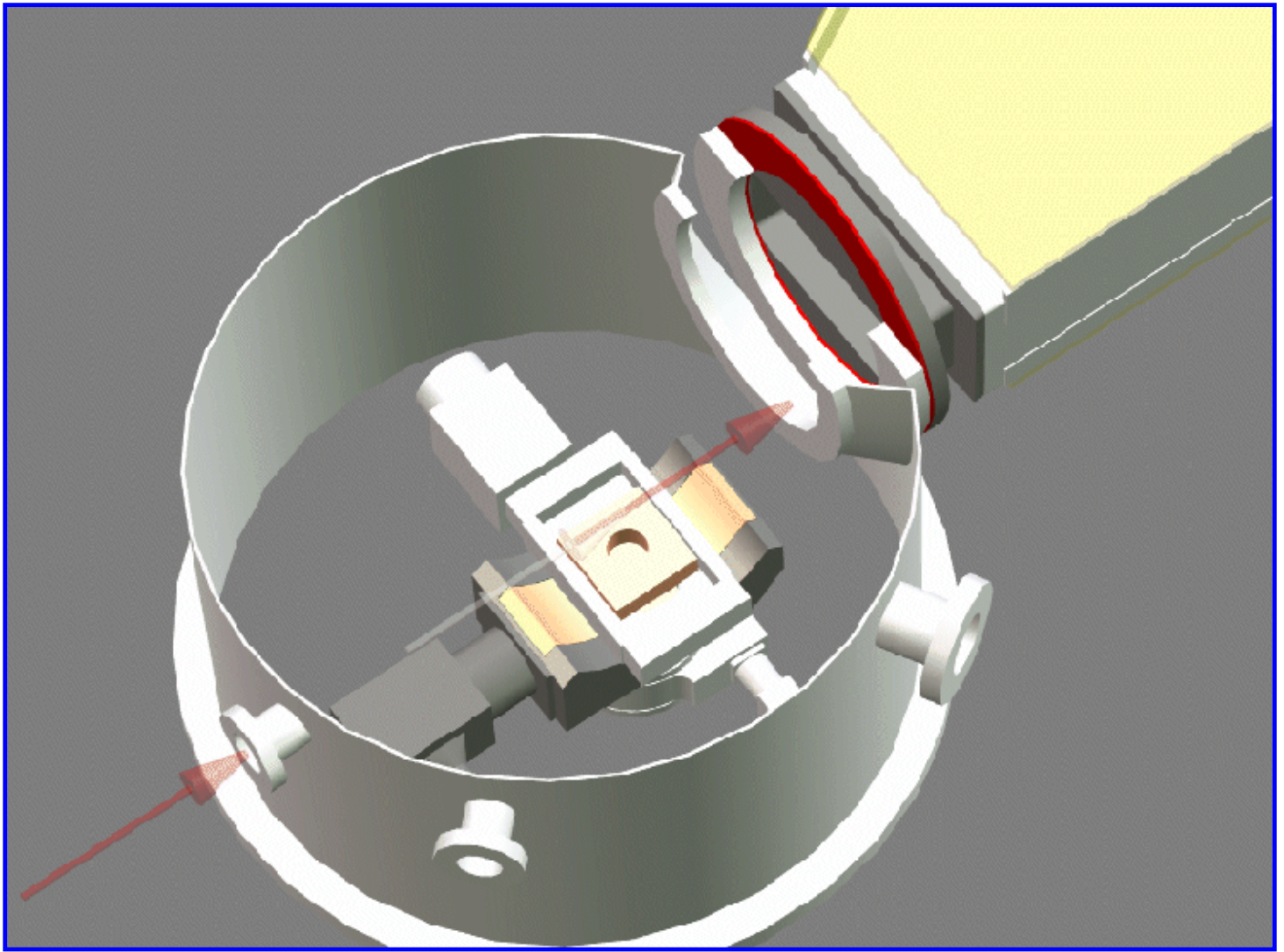

View into the goniometer chamber with beam path.

[3D VRML view](#)

Assembling postscript drawings

D.C. setup (for printing) with main dimensions :

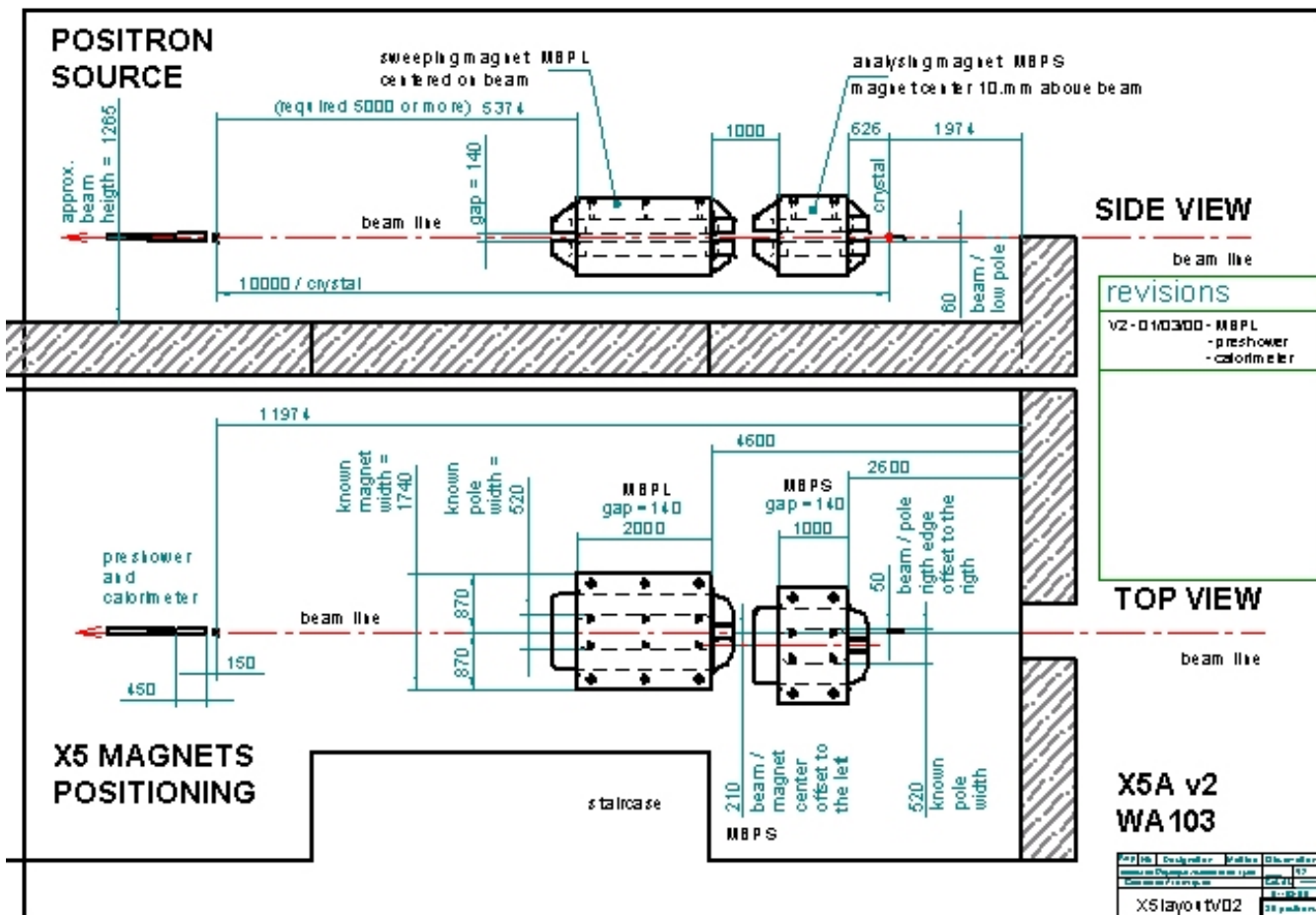

Top and side ([X5drawingLayoutV02.ps](#))

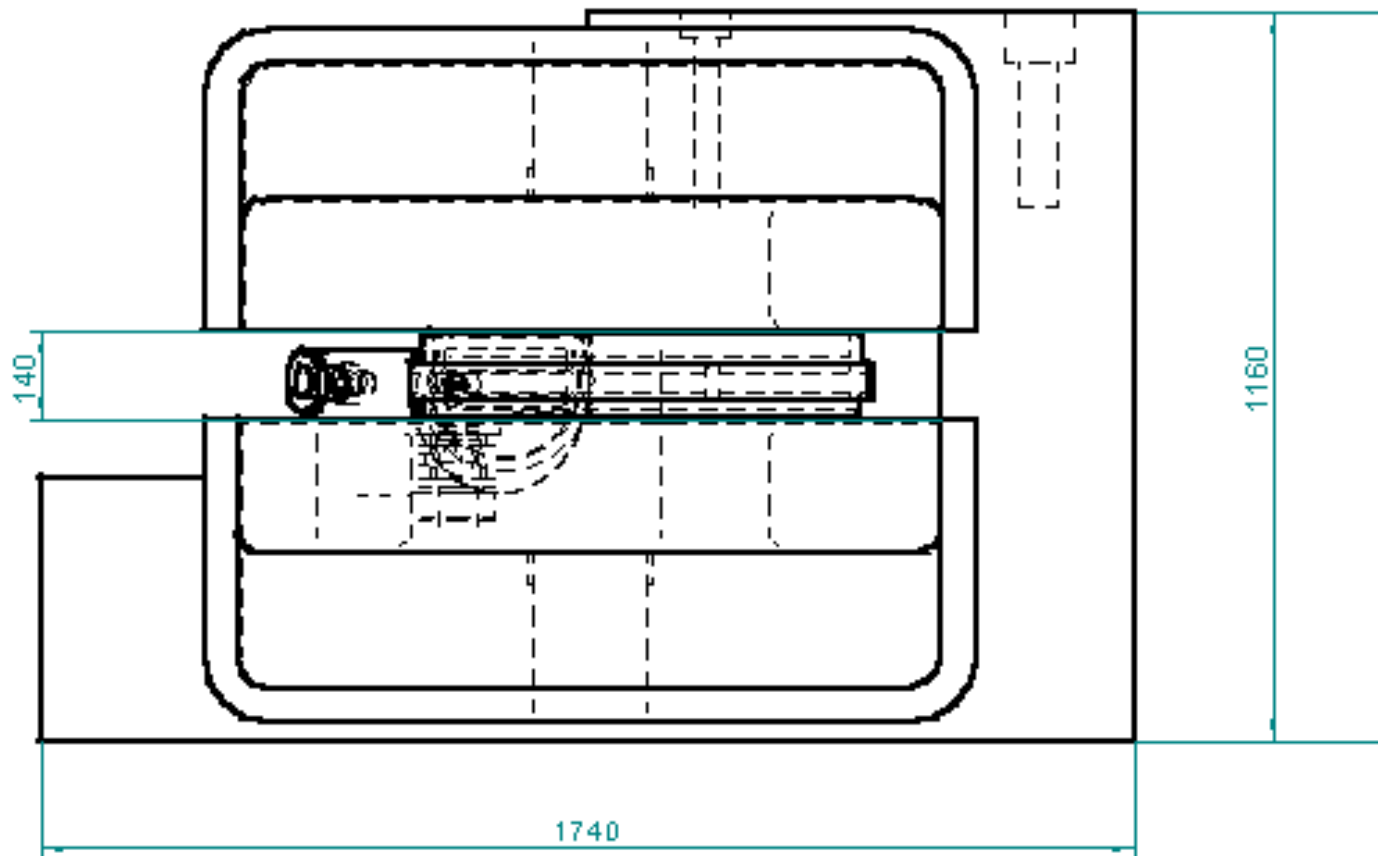

Back drawing ([postscript](#))

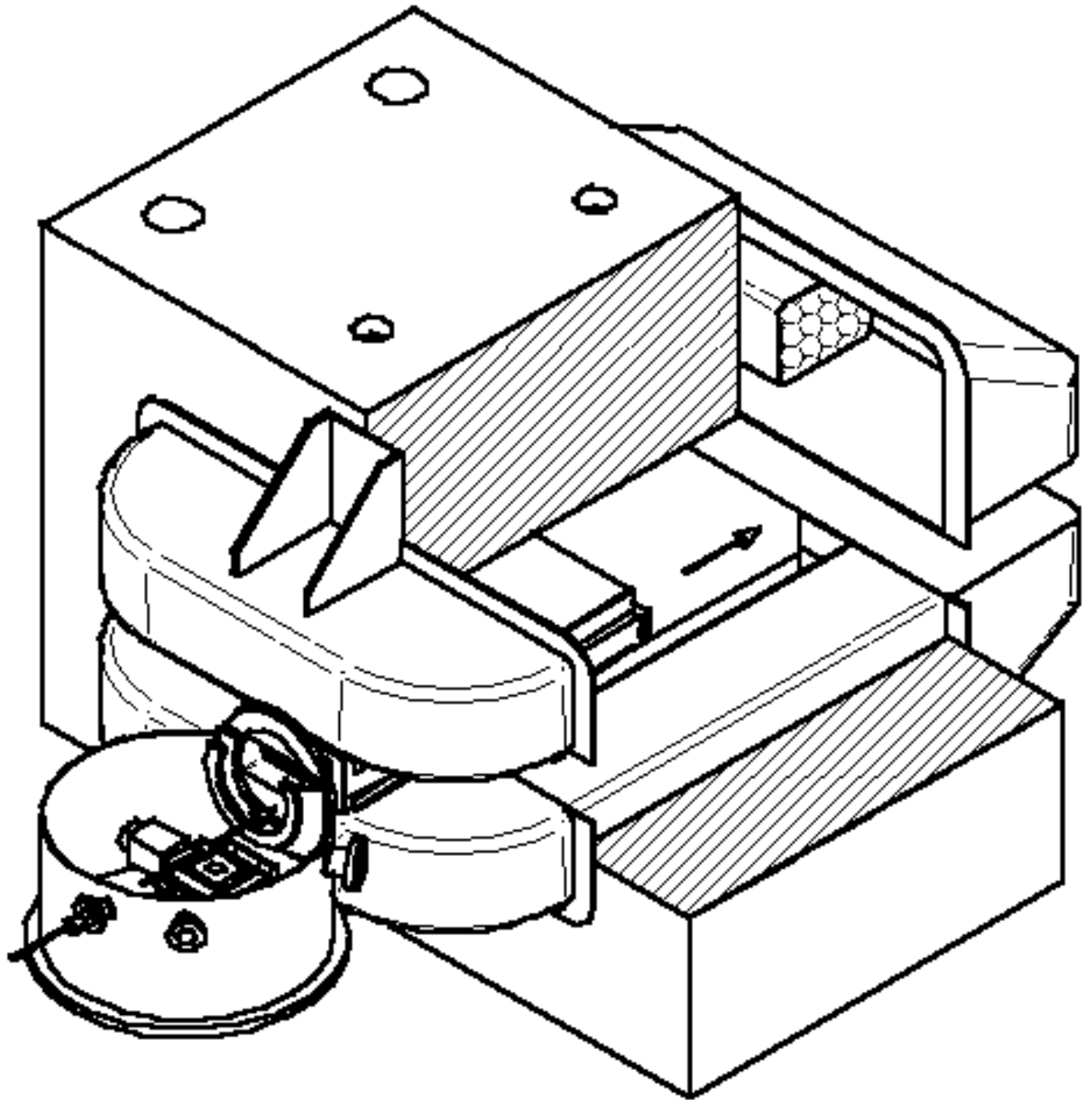

Isometric drawing ([postscript](#))

CERN SL EXPERIMENTAL AREAS GROUP

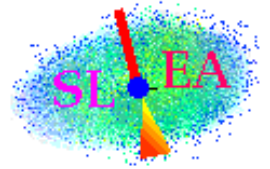

- [Mandate](#)
- [Group Organization](#)
- [Activities](#)
- [Operation](#)
- [News](#)
- [Search](#)
- [Phone](#)
- [Others](#)

TECHNICAL HOMEPAGE

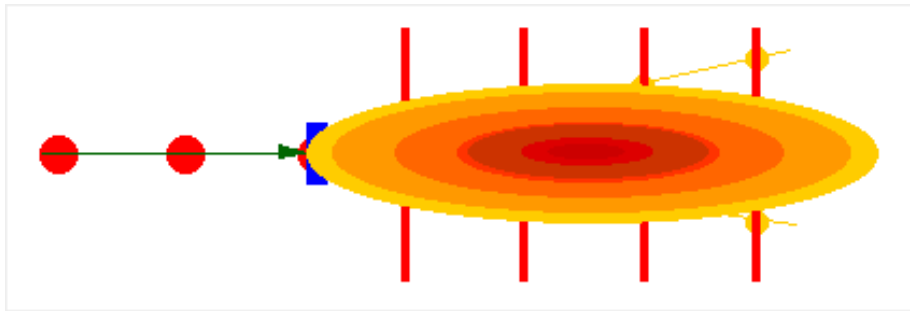

MANDATE

The EA group is responsible for the [secondary beam lines](#) downstream of the SPS primary targets T1 ([West Area](#)), T2, T4 and T6 (North Area). A synoptical diagram of the beamlines is available [here](#). These beamlines serve a variety of [experiments](#) and [test facilities](#). The group is responsible for the liaison with the users of these facilities and it provides support for their installation and infrastructure.

Part of the group is involved in the [CNGS project](#), providing a long baseline neutrino beam to the Gran Sasso laboratory near Rome.

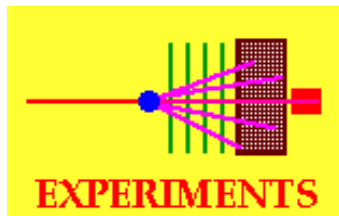

ACTIVITIES

The responsibilities for the various beamlines and zones are shared by five beam and liaison physicists:

West Area :	Per Grafström	H3
	Lau Gatignon	H3, X5, X7
North Area :	Niels Doble	H2, P42+K12
	Per Grafström	H4
	Ilias Efthymiopoulos	H6, H8
	Lau Gatignon	M2, P41/P61
LEP experiments :	Georg von Holtey	
CNGS project :	Konrad Elsener	

Click [here](#) for pictures of the Physicists in EA.



Both beamlines and experimental areas have to be adapted continuously to the needs and requirements of the experiments and tests. The work related to these changes is discussed in the [SPS Experimental Areas Technical Committee \(SEAT\)](#). The EA group comprises a [Engineering and Installation section](#), headed by [Michel Clement](#). Within this section, [Claude Ferrari](#) is responsible for the installation of the experiments.

The secretary of the EA group is [Madeleine Catin](#)

OPERATION

The exploitation of the secondary beam lines is assured 24 hours per day, 7 days per week with the help of the [CRN operations section](#), headed by [Bruno Chauchaix](#).

The present status of the beams is shown in [Teletext page 195](#). The contents of this screen are explained [here](#).

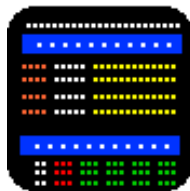

The state of the SPS machine operation ([PCR -> SL/OP group](#)) can be read from the so-called [Page-1](#) TV-screens. The contents of this screen are explained [here](#). Please click [here](#) for an overview of the last 24 hours.



TECHNICAL AND OTHER INFORMATIONS

 BEAMS	 HELP	 DOCS	 CRN OPS	 Techn.Sctn	 SEAT	 ACCESS	 LOGFILES
 Status/WB	 SCHEDULE	 New WA	 PICTURES	 HOT NEWS	 SYNOPTIC	 GIF	 PROJECTS

- [Secondary Beamlines in West and North Areas](#)
- [How to get help](#)
- [Documentation](#)
- [CRN operations section](#)

- [Engineering and Installation section](#)
- [Gamma Irradiation Facility](#)
- [Access Rules and Procedures](#)
- [Logfiles from control system](#)
- [Status screens and Whiteboard](#)
- [SPS Fixed Target Programme 1998](#)
- [Modifications to the West Experimental Area](#)
- [Some pictures of the beams and areas](#)
- [Hot News](#)
- [Projects](#)

For comments and changes send e-mail to [Lau Gatignon](#)

[Copyright CERN](#) -- [SL/EA](#), modified 24/11/97

Institut de Physique Nucléaire de Lyon

Collisions Atomiques dans les Solides

IN2P3 - CNRS UNIVERSITE CLAUDE BERNARD-LYON 1
43 Boulevard du 11 Novembre 1918 F 69622 VILLEURBANNE Cedex
[© Copyright CNRS](#)

Positron source software - WA103 CERN experiment

Documents, Images, CAO models and postscript files
R.K. Lyon July, 2000 softwareV3



Technical files

Software

1. General
2. Acquisition
3. Track reconstruction
4. Crystal Orientation
 - 4 - 1 • Scan rocking curve
 - Hardware
 - Scan parameters
 - Start position
 - Channel increment
 - Pre-count scaler
 - Pre-count value
 - Update period
 - Scanning the Crystal
 - Start scan
 - Stop scan
 - Resume scan
 - Abort channel
 - Do measurement in current channel
 - 4 - 2 • Data display and graphic interface
 - Interactive graphic display
 - Moving around manually
 - IND4 - Motor Control Window
 - Go to pre-defined position

Move to absolute position

Relative move

Hardware limitation

4 - 3 • Frequently used commands

- For scanning
- For counting without scanning

4 - 4 • Define-Menu extras[top](#)

1 General

The general scheme as defined december 21, 1998 at Orsay was modified at the Orsay meeting of dec 14, 1999. [Minutes](#) from R. Kirsch

[top](#)

2 Acquisition

Aquisition

as defined at meeting at LAL 14/12/99

(R. K. minutes to be approved, Villeurbanne dec. 20 1999).

1 - Manpower :

from	surely		to be confirmed	
LAL Orsay	1	Robert	1	
Lyon IPNL	2	variable	0	
Novisibirsk	2	Slava	1	
		Sergei		
Tomsk	1	Vnukov	1	
Karkhov	1	Masslov	1	
TOTAL	7	+	4	= 11

2 - Event trigger :

Scintillators :

As proposed 25-6-99 by M. Dubrovin : C1, A1 and C2, A2 certifies that a proper electron with the right trajectory has entered the crystal.

C1, C2 are square scintillators for coincidence

A1, A2 are scintillators with a hole for anti-coincidence

A2 hole diameter = 3 mm in front and close to the crystal.

A1 hole diameter = 20 mm depends on distance and accepted divergence.

3 – Computers :

Two local PC's and a remote UNIX server.

We will use of only two "on line PC's" :

1. DELL PC for data acquisition and data file storage and transfer.
2. GONIO PC for goniometer control :
3. crystal orientation, rocking curves, target swapping.
4. Serial RS232 link between PC's for goniometer position read out
5. Ethernet connection for DELL PC data file transfer and for remote analysis
6. X terminal
7. UNIX server
8. Ethernet connection

4 – Online information on DELL PC

Acquisition program :

Display of :

1. Number of trigger events per beam burst
2. Histogram of event lengths
3. Histogram of gamma energies
4. Histogram of scaler per burst (counting of veto and trigger scintillators)

5 – Acquisition files analysis through X terminal on remote UNIX server

Drift chamber data analysis :

Needs several tasks to be implemented in "near on line program" :

1. Kmax data file access
2. Data reading
3. Data re-formatting
4. Track analysis and reconstruction

5. Display of Tracks in an event
6. 2 D Histogram of recognized track distribution (versus angle and energy)

6 – Ethernet connection :

CERN provides operational Ethernet sockets (three minimum) in the barrack.

The use of only two "on line PC's" (DELL PC and GONIO PC) needs to ask at CERN for a operational Ethernet socket.

Kmax acquisition files have to be transferred from acquisition DELL PC to a UNIX server. This can be done, when needed, manually by FTP or, if possible by program, automatically.

7 – Software tasks modifications :

They where defined in Orsay on December 21, 1998 but PC2 below disappears

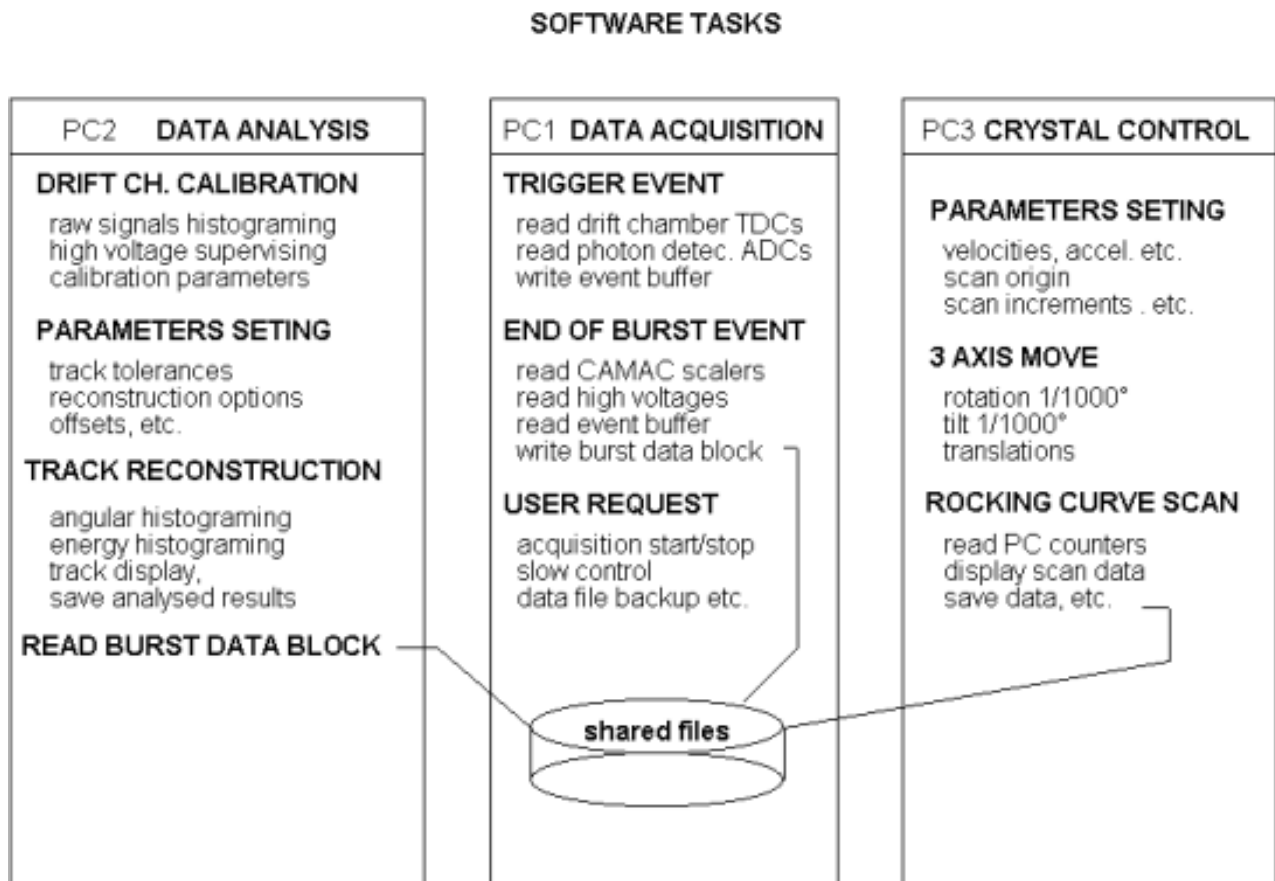

and tasks are modified according to the new scheme :

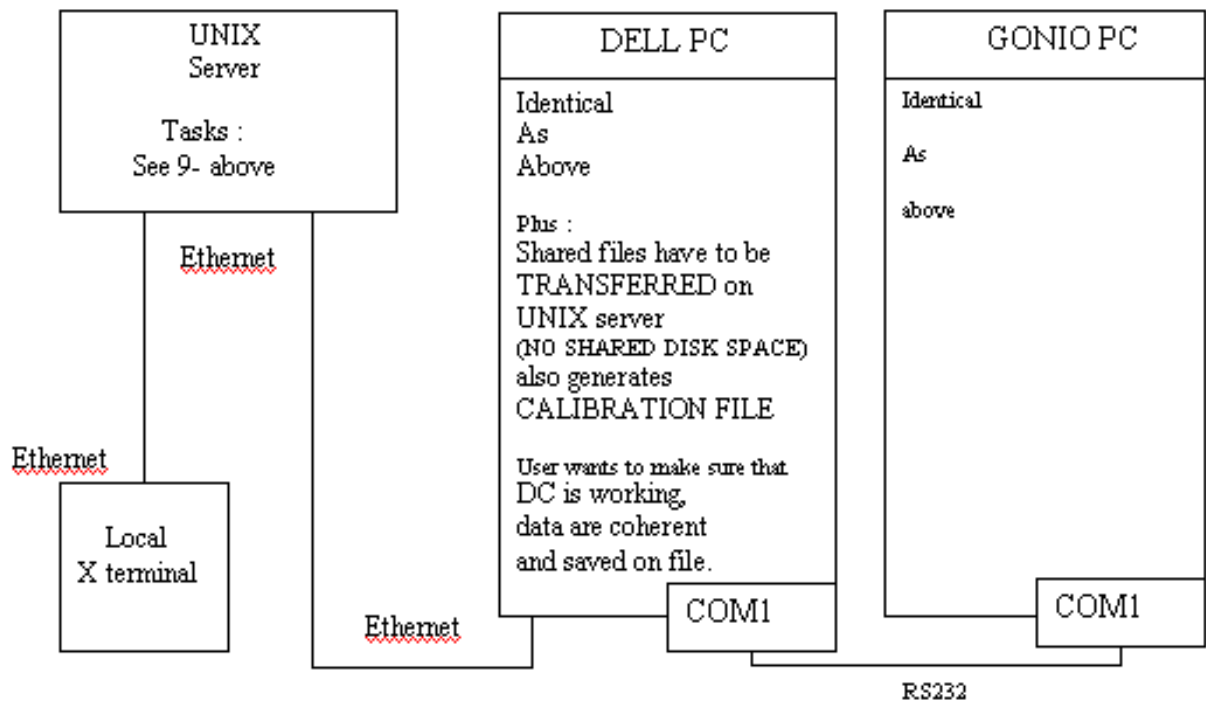

8 – Experiment functional map :

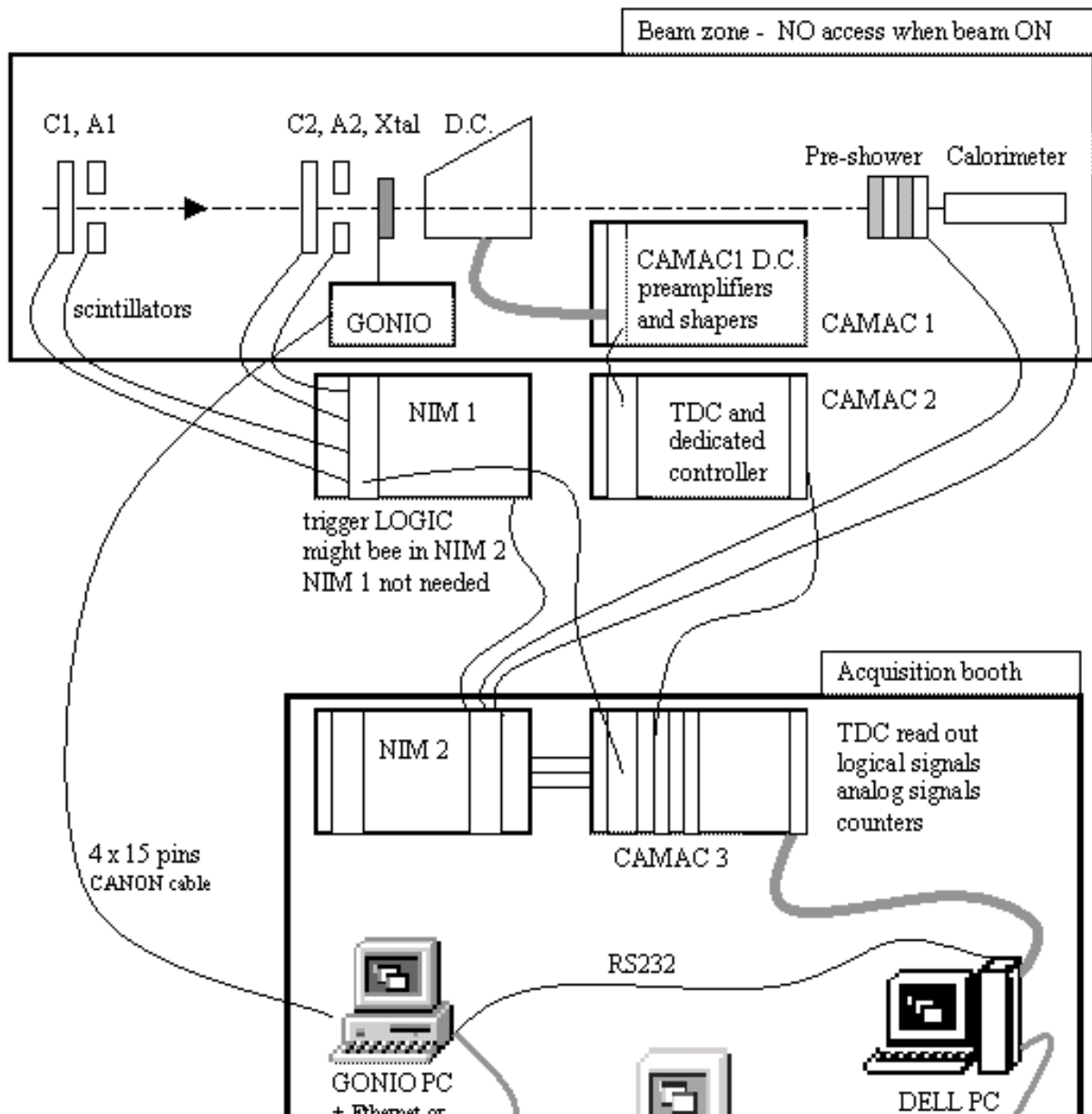

v2 dec.22, 1999
R. K. minutes.

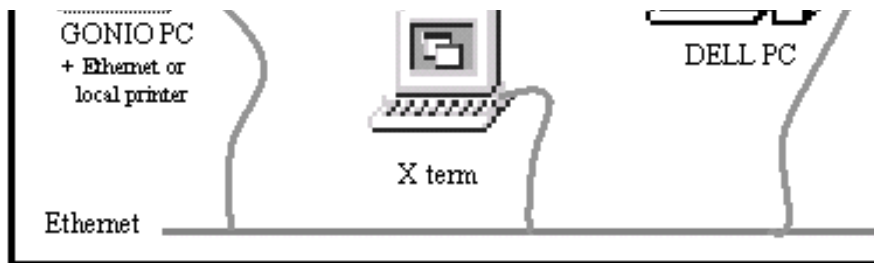

[top](#)

3 Track reconstruction

Postscript document : V.V.Shary august 16 1999 [full](#) (1.5Mo) [first page](#)



[top](#)

4 Crystal orientation

4 - 1 Scan rocking curve :

- **Hardware**
- **Scanning parameters**
 - Start position
 - Channel increment
 - Pre-count scaler
 - Pre-count value
 - Update period
- **Scanning the Crystal**
 - Start scan
 - Stop scan
 - Resume scan
 - Abort channel
 - Do measurement in current channel**

Event counts (rates if pre-time measurement) can be recorded versus crystal orientation (goniometer position). Up to 5 TTL signal counting channels can be activated and plotted on the display [interface](#) in a multi-channel multi-scaler plot chart (could be improved to 10 if really needed).



[top](#)



[scan or rocking curve](#)

Hardware :

The PC counting card :

- Supplier : Computer Board
- Model : CIO - CTR10

- Chip base : two AMD 9513
- Counters : ten 16 bits counters
- Wiring : cascaded 2 by two to implement five 32 bits counters
- I/O signals : TTL CMOS
- 16 bits digital input
- 16 bits digital output
- Internal clock Xtal stability : 100ppm
- Windows driver : Computer Board Universal Library DLL
- Bus : ISA

The PC motion control card :

- Supplier : Micro-Controle
- Model : IND4-C (1990)
- Chip base : no processor on board
- Axis : 4 (low speed, high speed, acceleration per axis)
- Limit control : high and low limit switch handling
- Type of output : forward and backward clock signals
- Windows driver : JPG Micro-Services DLLIND.DLL library
- Power drive : Micro-Controle TL78 power rack
- Bus : ISA



[top](#)



[scan or rocking curve](#)

Scan parameters :

In order to acquire a rocking curve plot (or scan), one has to define the scan parameters before starting the goniometer scan sequence :

1. Start position

Parameter	Value	Unit
Translation	0	microns
Tilt	0	10-3 deg
Rotation	0	10-4 deg
Unused	0

Enter new origin positions

is defined in a 4 start value window like this one. On scan start the goniometer will move there in order to count the first channel values.

2. **Channel increment** defines the relative goniometer move at the end of the measurement at one channel before the next measurement at next channel is started. This move can involve more than one motor (dx, dy, dz...) and is defined through a input value window similar to the one above

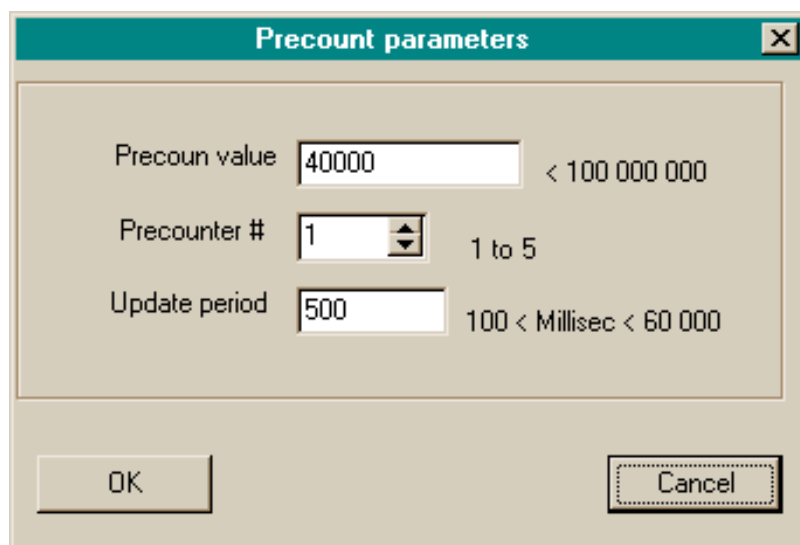

1. **Pre-count scaler** defines one of the 5 scalers as a normalizing scaler. That means for stopping all the counters when the pre-count defined value is reached on that counter
2. **Pre-count value** is used to stop and read the counting on all counters when that value is reached on the pre-count scaler. A clock signal at 10 kHz on that scaler can be used for pre-time measurements if no normalizing events (or frequency) are available.
3. **Update period** : on the dialog window above, is just used for convenience, to adjust the screen updating of counter values if they are displayed. A value of 1000 gives in counters display window the counting rate per second.

[top](#) [scan or rocking curve](#)

Scanning the Crystal :

Motor control and **Counter Display** menus toggle the show/hide property of the "IND4 - Motor Control" and the "CIO - CTR10 - Counter Display" windows respectively. The control buttons in the "Scan control" box control the use of scan facilities :

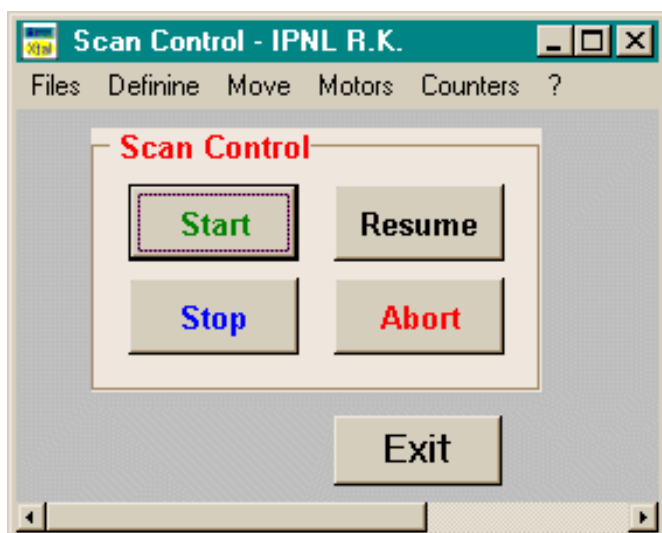

- **Start scan** button initiates a new series of successive measurements :
 1. proposes to save the previous data
 2. erases the previous data and displayed values
 3. moves the goniometer to the start position
 4. sets current channel to 0
 5. enable scanning : allow repeated measurements
 6. do measurement in current channel (* see below)
- **Stop scan** button
 1. disable scanning, that means : current channel will be the last measurement
 2. waits for the end of current channel measurement:
- **Resume scan**
 1. enable scanning
 2. do measurement in current channel (see below)
- **Abort scan**
 1. disable scanning
 2. abort current measurements discard counter values
 3. current channel is not incremented and stays empty

* **Do measurement in current channel** : This action is a standard procedure which

1. increments channel number
2. resets all counters
3. enables all counters
4. activate a refresh timer with the parameter "Update period"
5. on timer event :
 - refresh counter contents in "CIO - CTR10 - Counter Display"
 - refresh plot chart
6. compares pre-counter value with pre-count to produce the "Precount OK" event
7. on "Precount OK" event :
 - reads counters
 - correct for pre-count overflow
 - update current data
 - save data
 - if scanning is enabled :
 - go to next position by moving the goniometer by one pre-defined increment
 - do measurement in current channel (again)



[top](#)



[scan or rocking curve](#)

4 - 2 Data display and graphic interface :

● **Interactive graphic display**

● **Moving around manually**

IND4 - Motor Control Window

Go to pre-defined position

Move to absolute position
Relative move
Hardware limitation

 [top](#)  [data display and graphic](#)

Interactive graphic display and parameter information on scan results :

On the displayed plot window in the user interface, the user can

1. select a plot of interest (plot #, all functions will work on that plot)
2. view or hide a selected plot
3. scale up, down or optimize the ordinates
4. print a hardcopy
5. explore the channel content and corresponding goniometer position with a main hair-cross cursor, the text has the same color as the selected plot
6. measure channel and position differences between main and auxiliary cursor
7. see the current channel number and goniometer position (cni #)
8. see the scan start, increment and pre-count parameters
9. resize the plot window
10. the abscissa scale is automatically adjusted

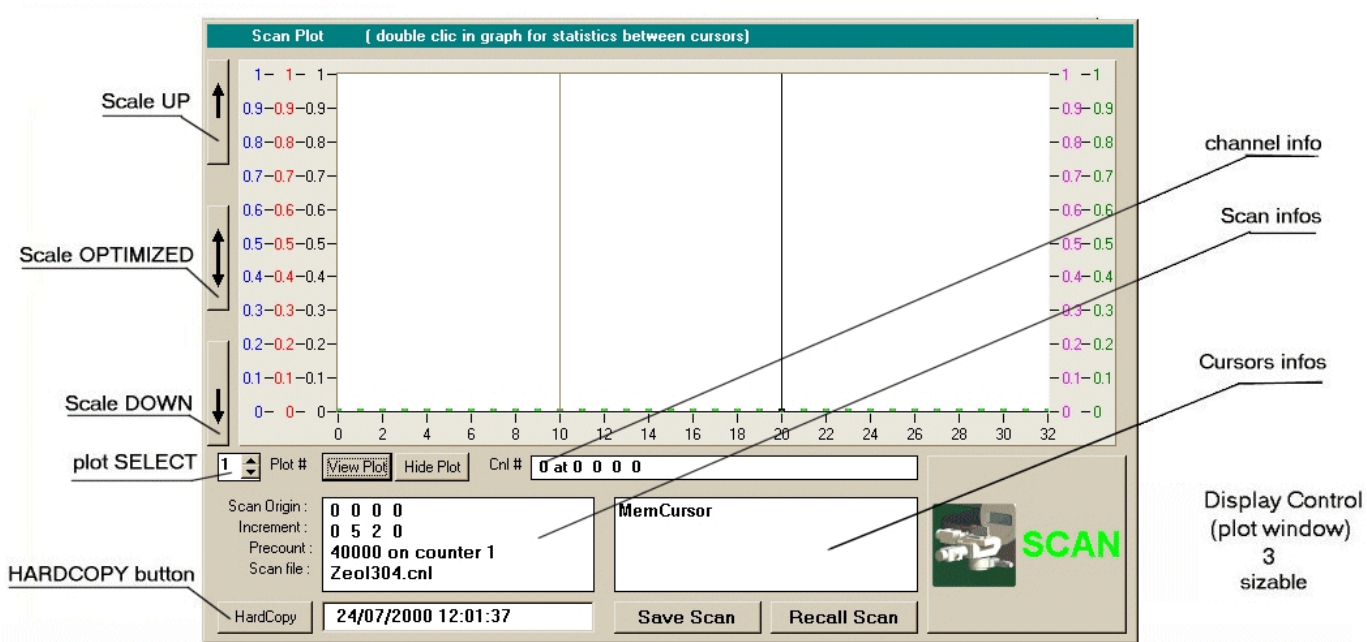

Save data / Recall data

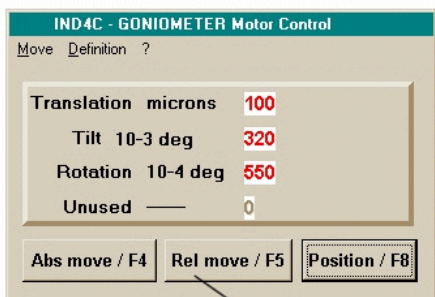

Motor Control
(position window)
4 Popup / hideaway

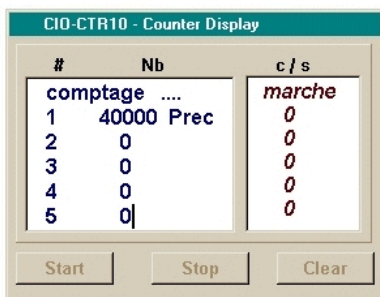

Counter Display
2



Scan Control main window
1

Manual move button group

1. Moving around manually :

1. IND4 - Motor Control Window :

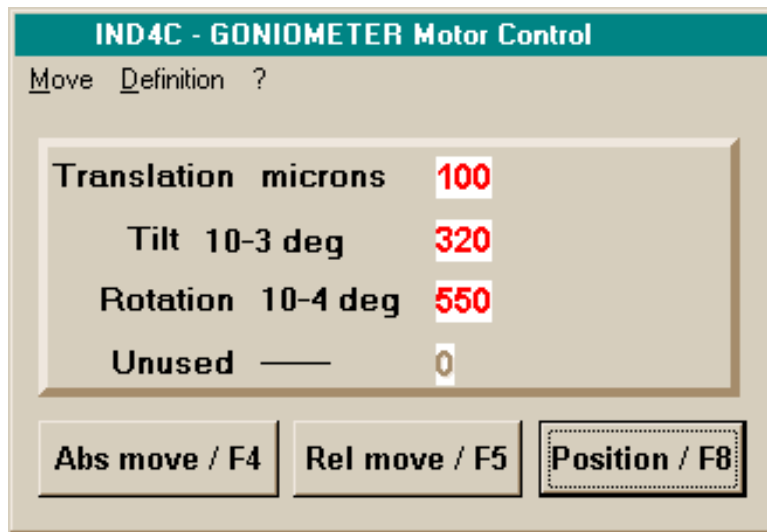

This window shows the current position of the goniometer motors. It also presents menu options and button controls.

The "Definition" menu is used to define

- motor parameters
- predefined positions
- predefined increment (used during scans)

The "Movement" menu, as well as the buttons, give a manual control over goniometer movements :

- Absolute movements by button click or F4 key
- Relative movements by button click or F5 key
- Predefined button click for new position move or F4 key
- Increment button for one single predefined incremental move or F9 key.

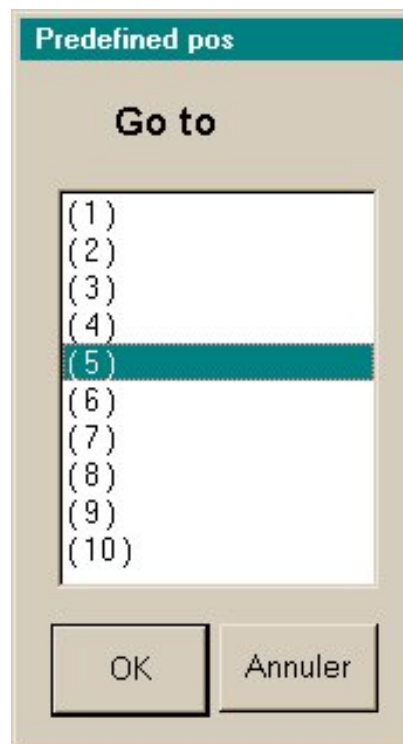

1. **Go to pre-defined position :**

It is possible to pre-define frequently used crystal positions and then go to those positions through this "Go To" window which pops up when clicking on "Predefined F8" button of "IND4 - Motor Control" box. The Definition menu of "IND4 - Motor Control" lets one pre-define the absolute values for the motors and name that pre-defined position.

2. **Move to absolute position :**

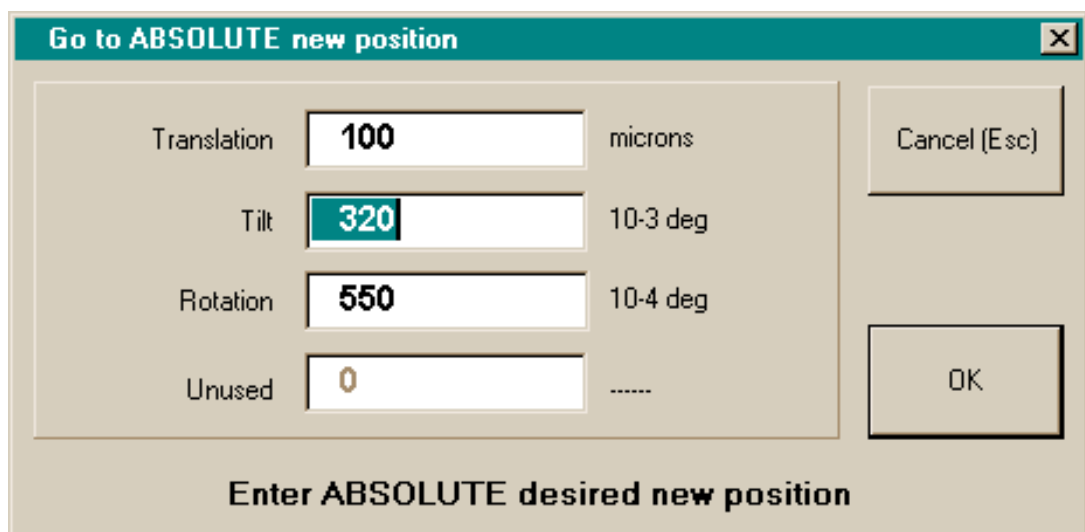

Enter desired new absolute position and click OK. After calculating the direction of rotation and number of steps to reach the new position for each motor the goniometer will move.

3. **Relative move :** In a similar window then the one above, enter the relative signed amplitude of desired move on each motor and click OK. The new position will be computed by adding the entered relative signed amplitude to the current position and calculating the direction of rotation and number of steps for each motor.

1. **Hardware limitation** : We use an existing old PC card from Microcontol with no processor on board. This means that during the move of the motors the PC processor is involved and no other task is running during that time.

Crystal orientation

4 - 3 • Frequently used commands

For scanning :

In order to do the rocking curves on a crystal we only need to

1. define the scan parameters : Define MENU for Precount, Origin and Increment values
2. start the scan : START button
3. stop the scan : STOP button
4. save the Spectra : SAVE scan button

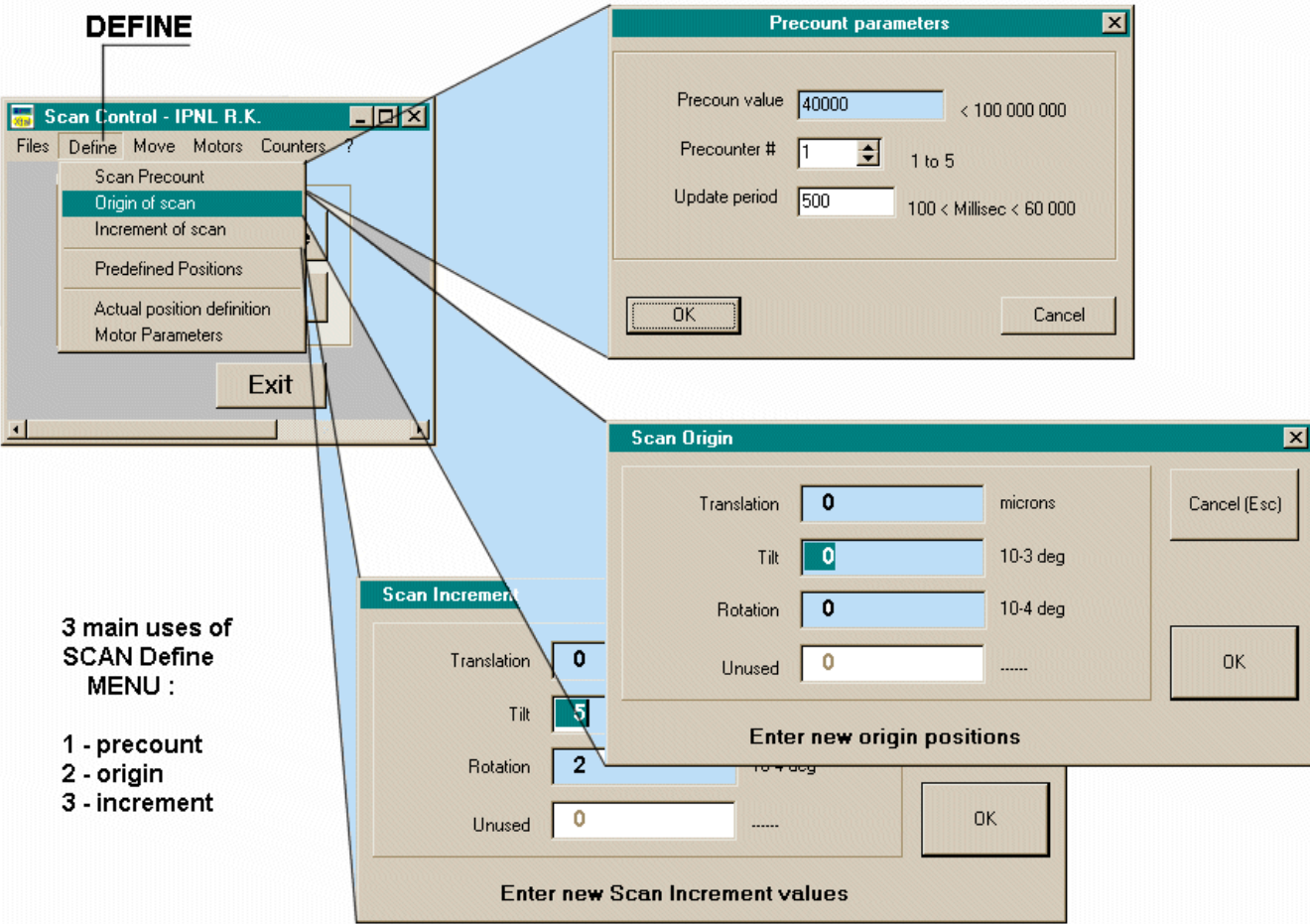

DEFINE

Scan Control - IPNL R.K.

Files Define Move Motors Counters ?

- Scan Precount
- Origin of scan
- Increment of scan
- Predefined Positions
- Actual position definition
- Motor Parameters

Exit

Precount parameters

Precount value: 40000 < 100 000 000

Precounter #: 1 1 to 5

Update period: 500 100 < Millisec < 60 000

OK Cancel

Scan Origin

Translation: 0 microns

Tilt: 0 10-3 deg

Rotation: 0 10-4 deg

Unused: 0

Enter new origin positions

OK Cancel (Esc)

Scan Increment

Translation: 0

Tilt: 5

Rotation: 2

Unused: 0

Enter new Scan Increment values

OK

3 main uses of SCAN Define MENU :

- 1 - precount
- 2 - origin
- 3 - increment

For counting without scanning :

While not scanning, one can use the START, STOP and CLEAR buttons on the Counter display window to make countings and counting rate evaluations on the five counters. In the precount parameter window above, the update period has to be set a 1000 ms for displaying a rate per second.

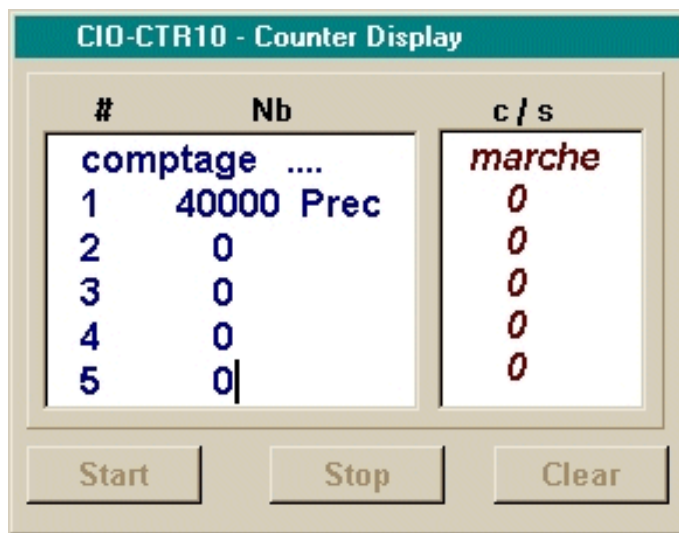

The START, STOP and CLEAR buttons on the Counter display are disabled during the scan counting.



[Crystal orientation](#)

4 - 4 • Define Menu extras

Actual position definition :

If the logical position values, known by the program, disagree with the hardware motor positions, one can force the program to the actual motor positions. This needs a password (MECANO).

Motor parameter :

This window is never used by the regular program user. It needs a password and concerns the hardware adjustment of motors speed, acceleration etc... This is done by maintenance people at hardware installation.

Institut de **P**hysique **N**ucléaire de **L**yon

Collisions **A**tomiques dans les **S**olides

IN2P3 - CNRS UNIVERSITE CLAUDE BERNARD-LYON 1
43 Boulevard du 11 Novembre 1918 F 69622 VILLEURBANNE Cedex

[© Copyright CNRS](#)

Positron source crystals - WA103 CERN experiment

Documents, Images, CAO models and postscript files

R.K. Lyon 14/04/2000

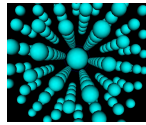

[3D view](#)



Crystals

Mounted on target holder :

This holder and sample combinations give acces to several target configurations via the horizontal translation on top of the goniometer :

1. raw beam without target
2. 4 mm single crystal W
3. 4 mm polycrystalline W
4. 8 mm single crystal W
5. 4 mm single crystal W + 4 mm polycrystalline W

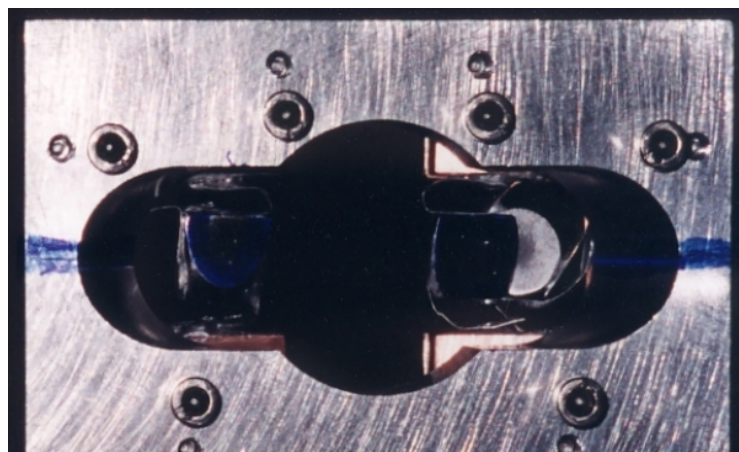
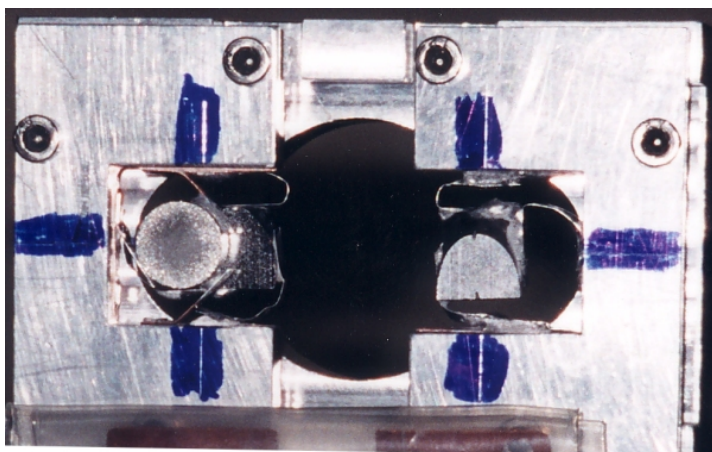
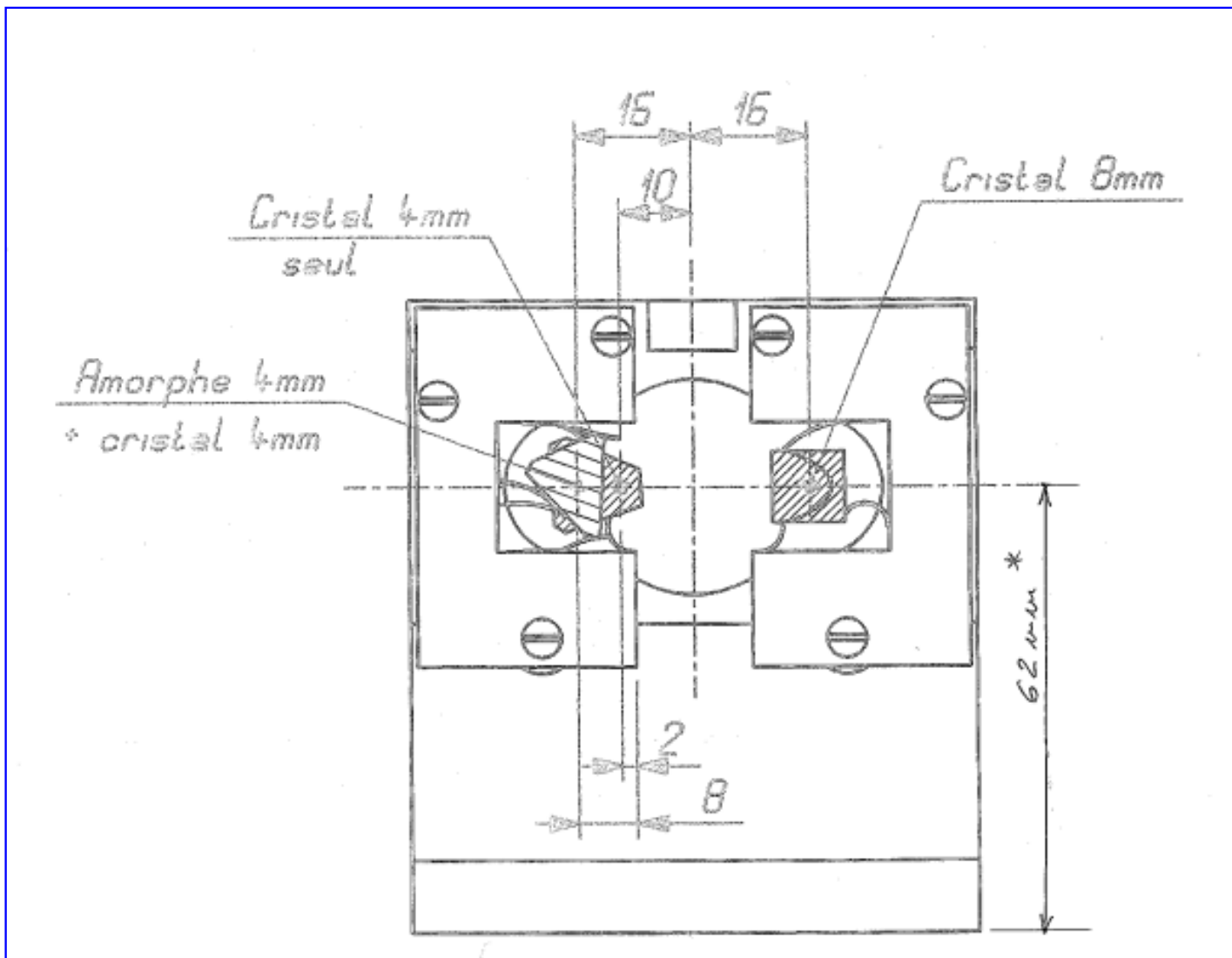

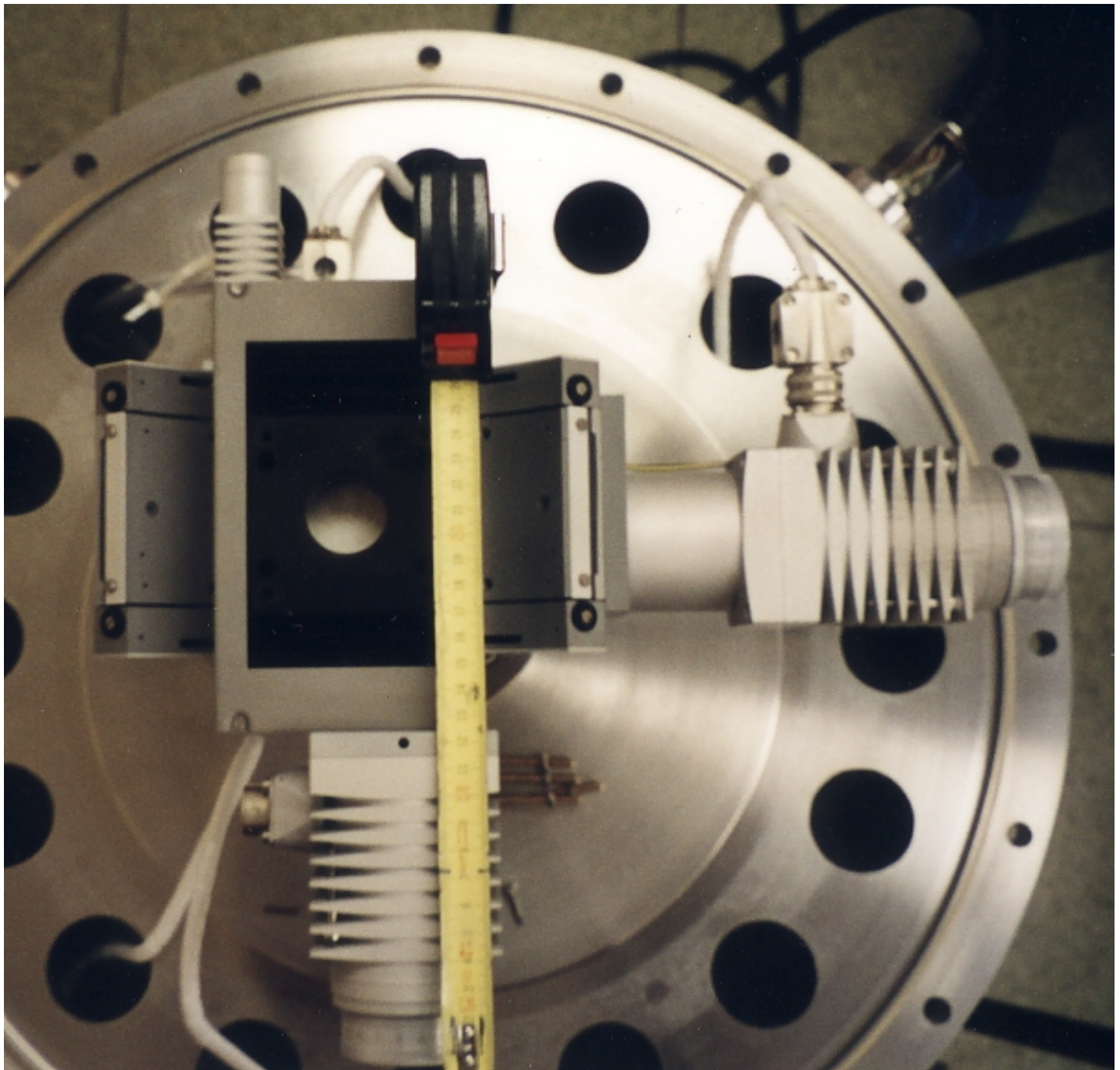

goniometrer table on which the crystal holder is mounted

Laue (by Peter Keppler, MPI Stuttgart) :



4 mm crystal,



8 mm crystal Laue diffraction pattern

Gamma diffraction (by Peter Keppler, MPI Stuttgart) :

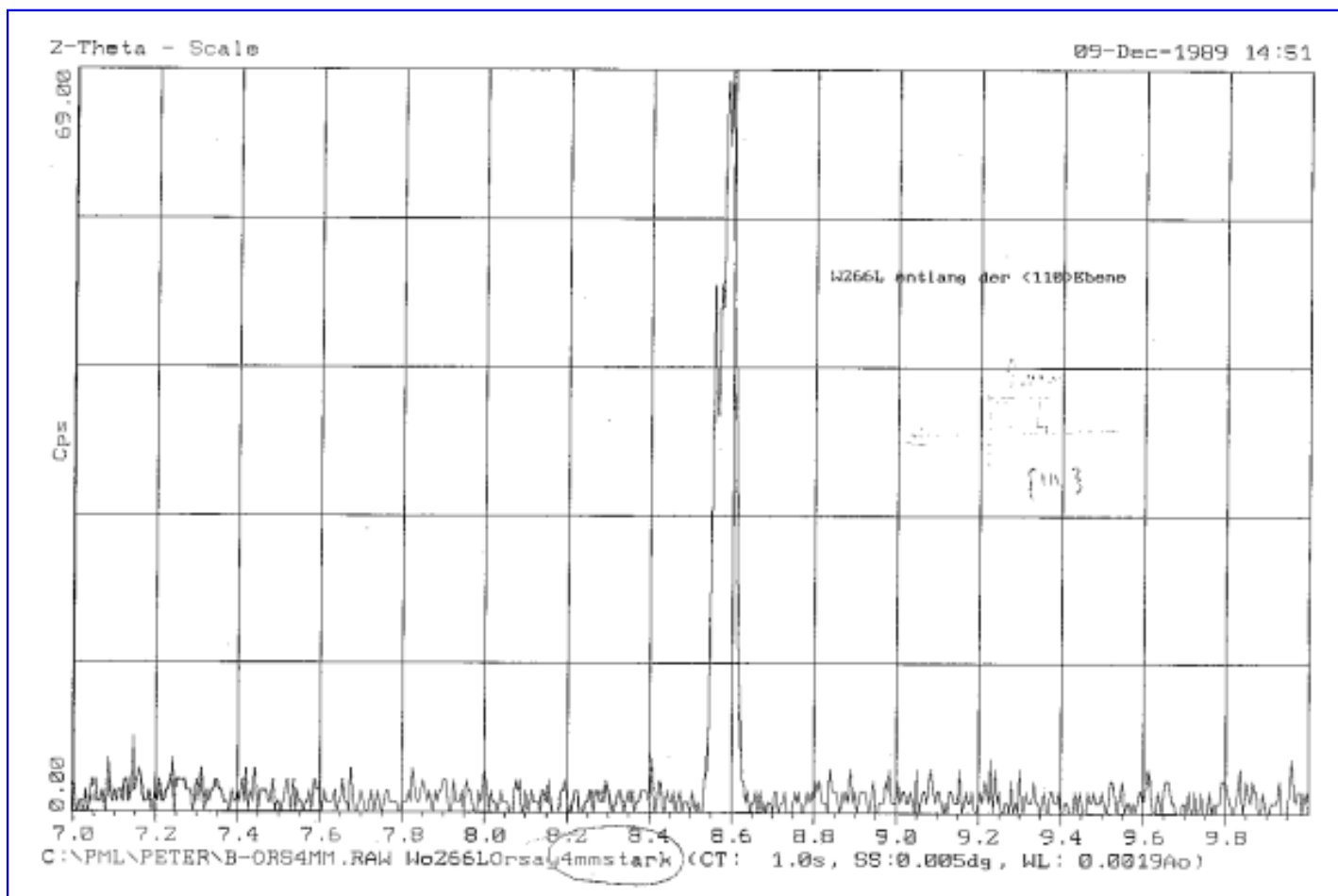

4 mm longitudinal gamma diffraction,

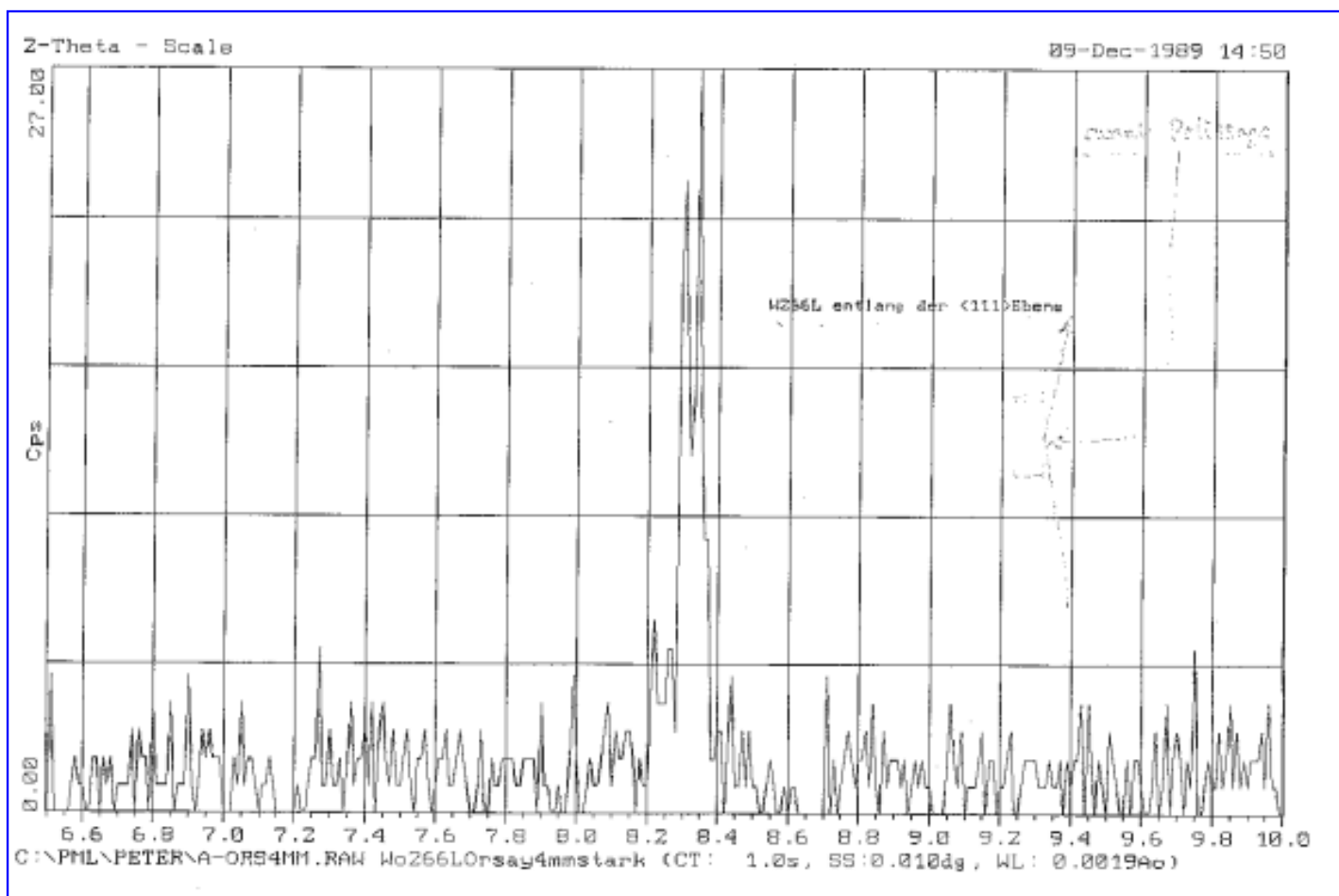

4 mm transversal gamma diffraction,

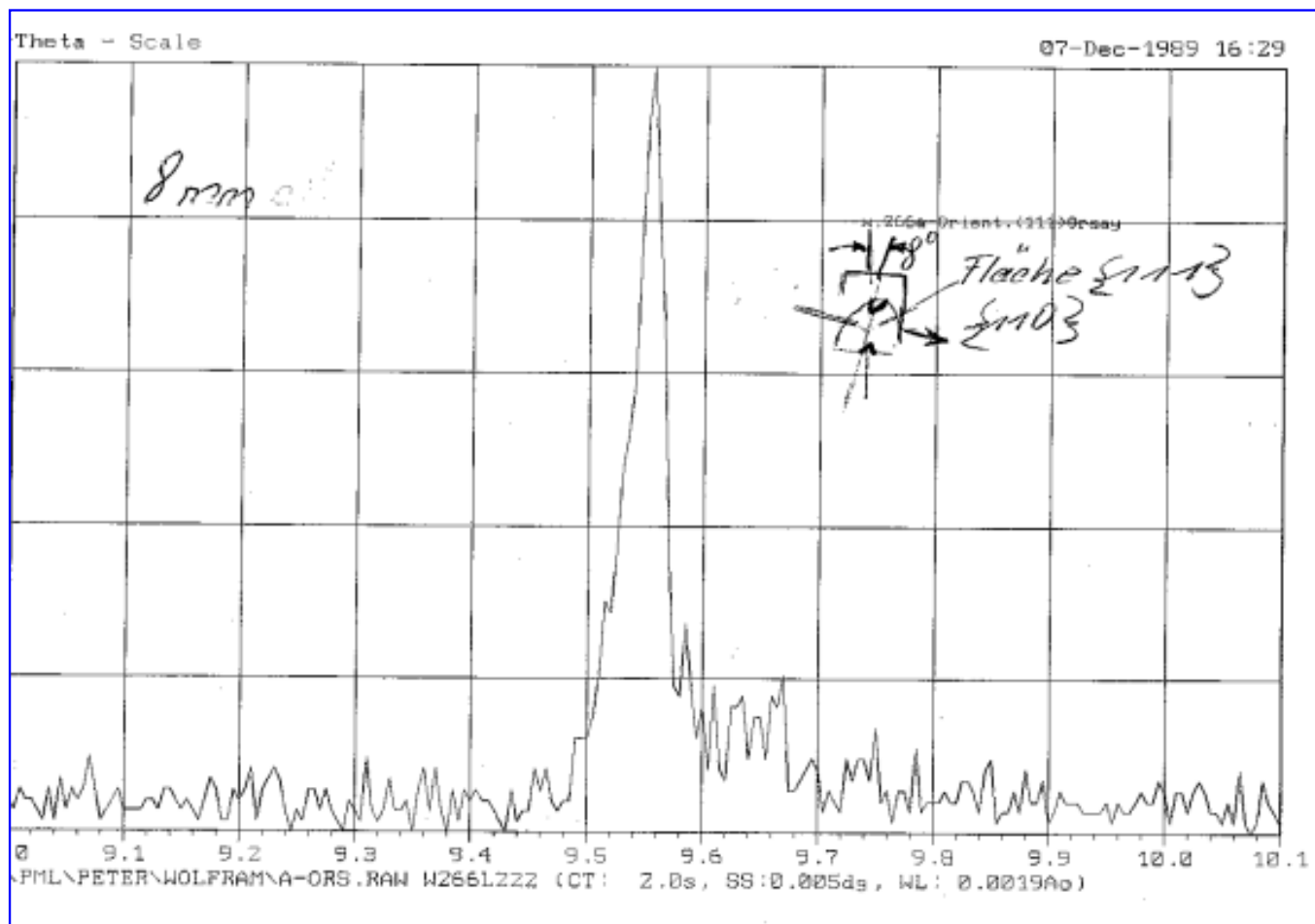

8 mm longitudinal gamma diffraction,

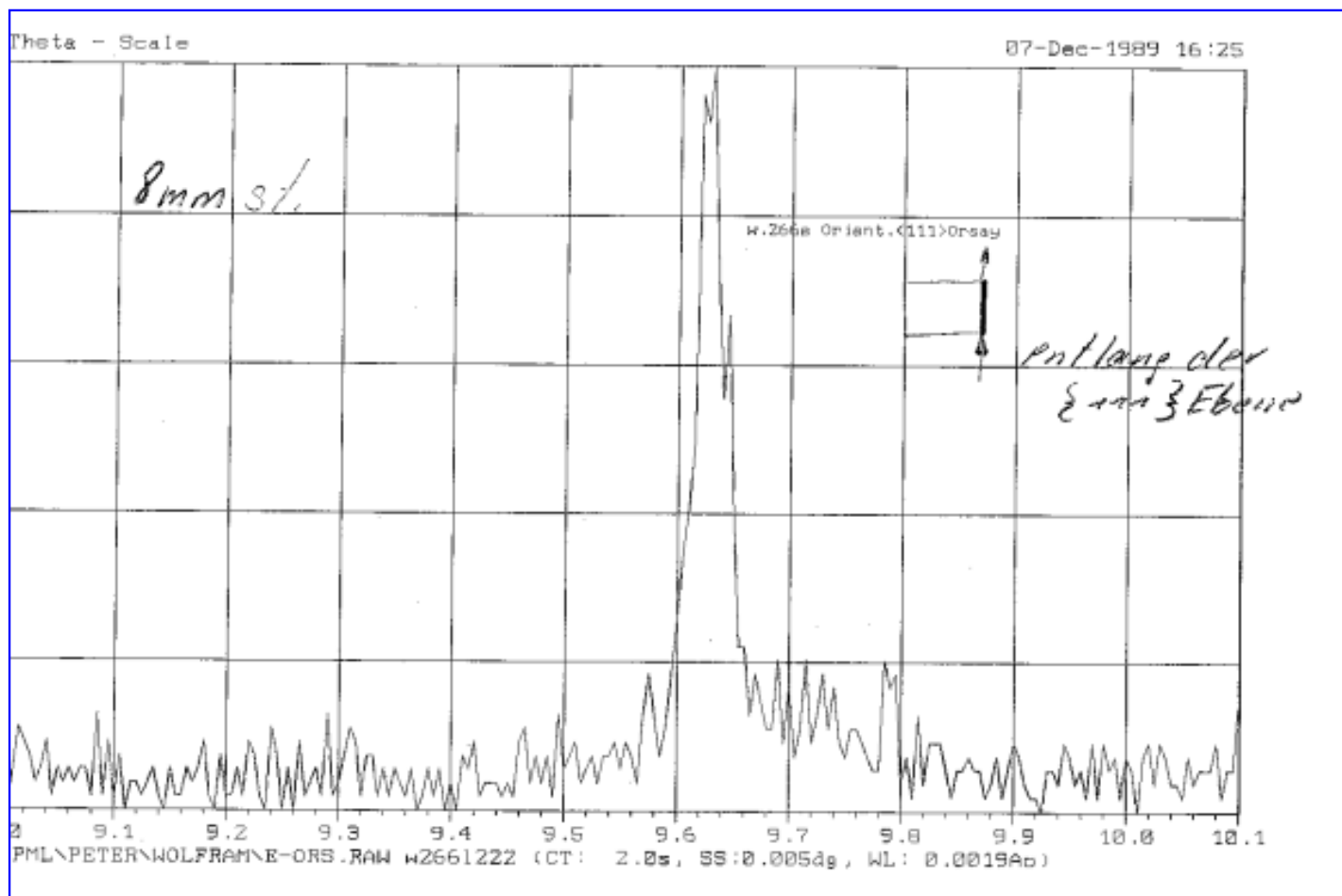

8 mm transversal gamma diffraction,

Tungsten models (by R. Kirsch, IPN Lyon) :

to see the
W
structure
just move
the mouse
over the
links
below

[110](#)
axis
view

[100](#)
axis

view

[111](#)

axis

view

111

[more](#)

atoms

111

[many](#)

atoms

clicking
3D needs
an
interactiv
VRML
browser

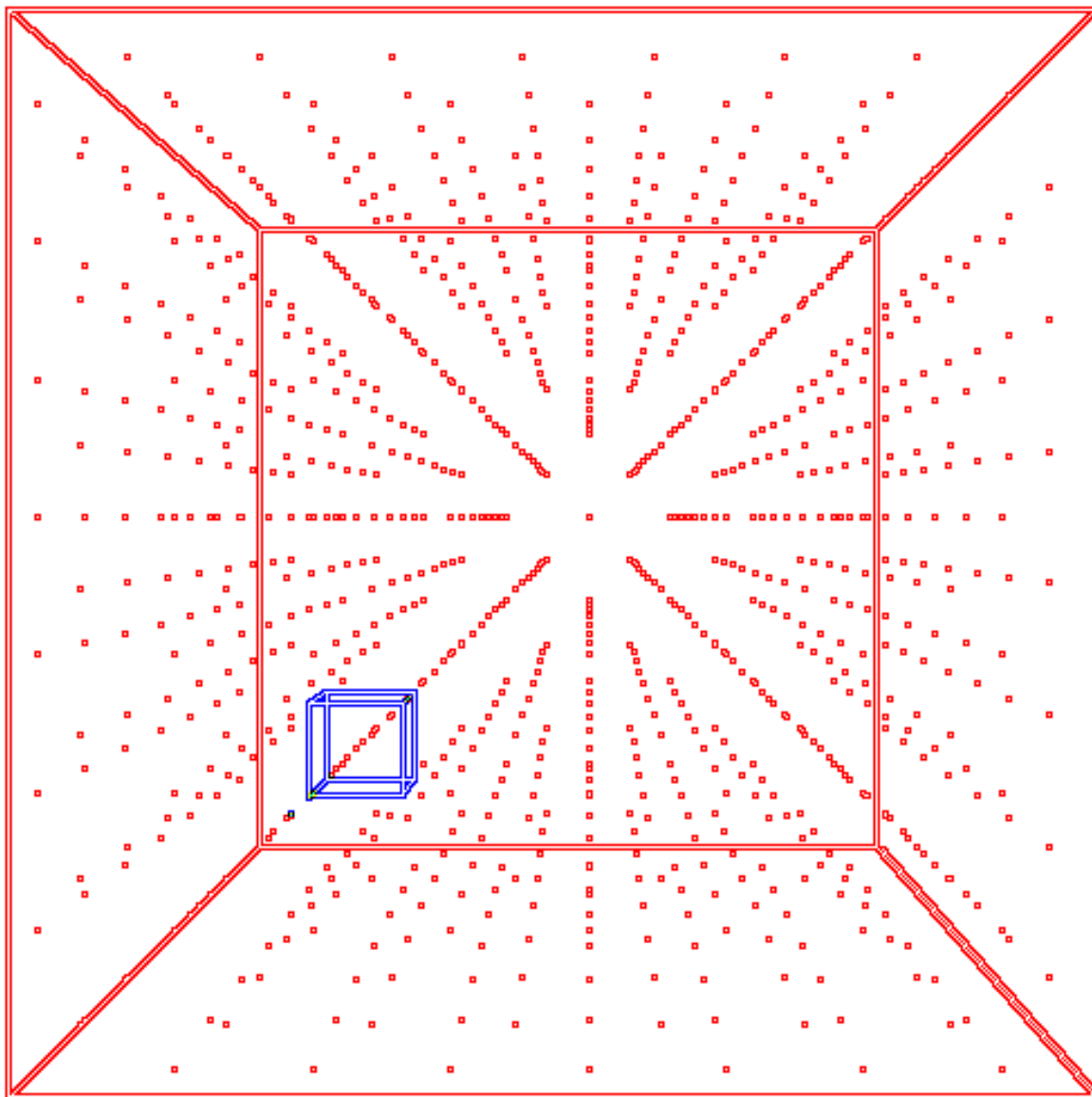

more

[3D](#)

many

[3D](#)

100 axis view

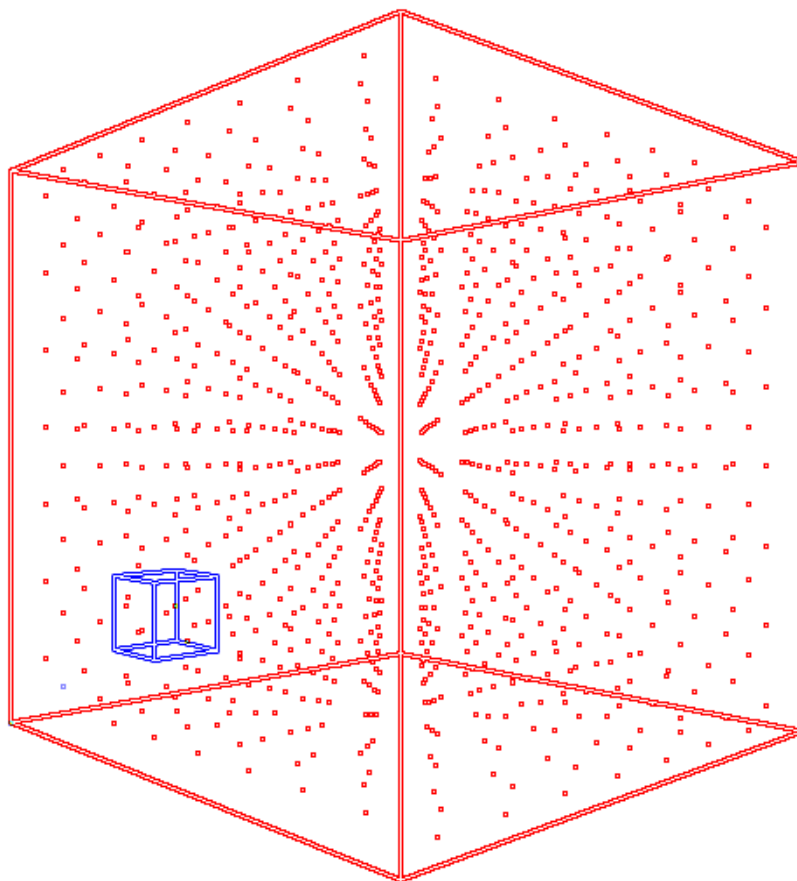

110 axis view

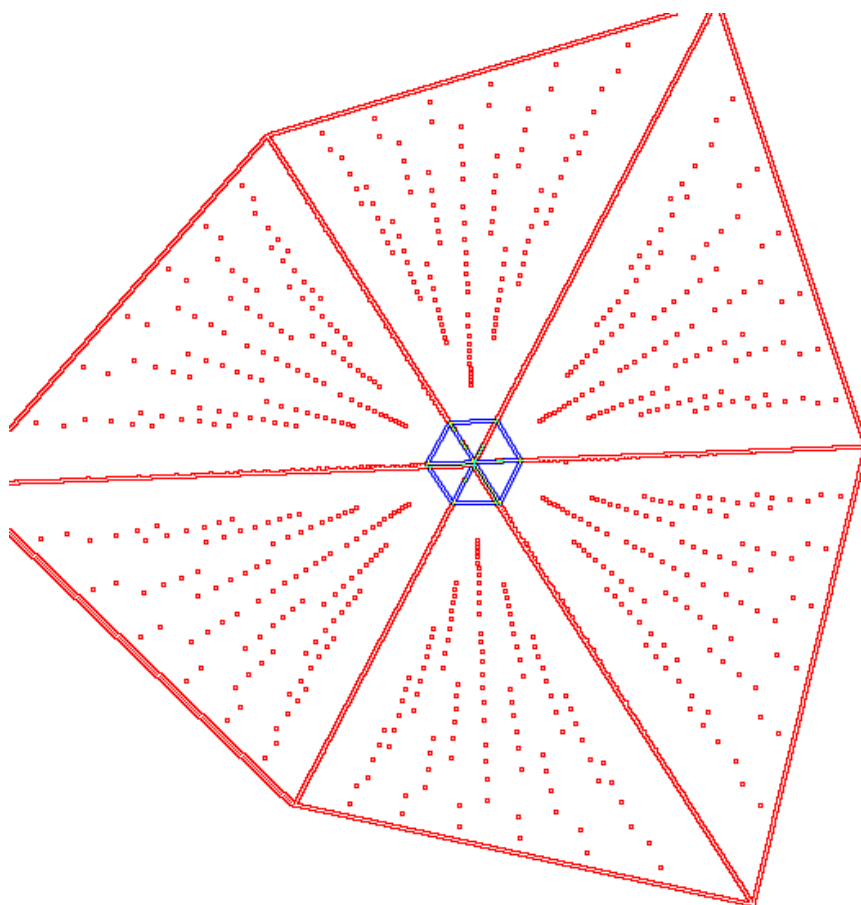

111 axis view

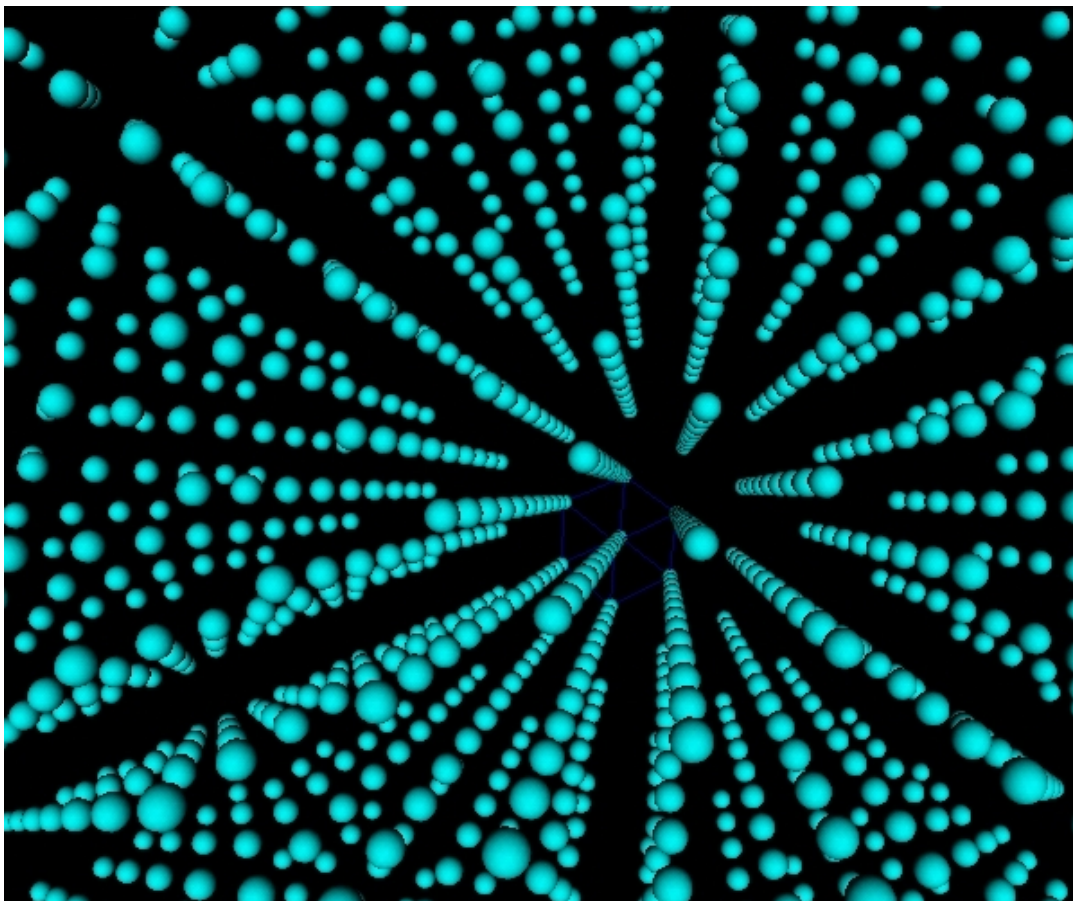

111 **more** atoms

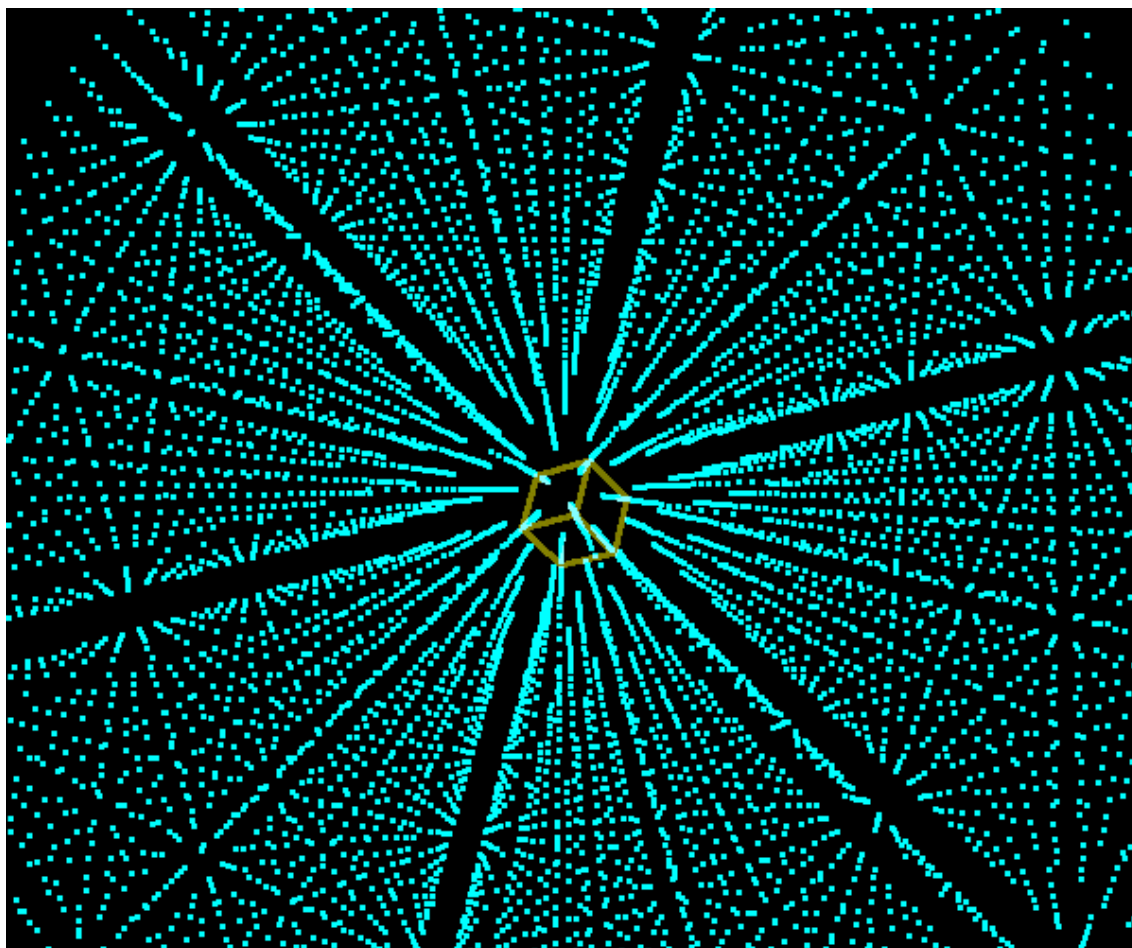

111 **many** atoms

Institut de P hysique N ucléaire de L yon

Collisions A tomiques dans les S olides

IN2P3 - CNRS UNIVERSITE CLAUDE BERNARD-LYON 1
43 Boulevard du 11 Novembre 1918 F 69622 VILLEURBANNE Cedex
[© Copyright CNRS](#)

Positron source magnets - WA103 CERN experiment

Documents, Images, CAO models and postscript files
R.K. Lyon 17/10/00

Photon detectors

Preshower and calorimeter

Large preshower scintillator	square, 110 x 110 x 5 mm
Small preshower scintillator	circular, diameter 30 x 5 mm
Radiator	1 mm Al (in large scintillator) + 2 mm Cu
NaI calorimeter cristal	square 110 x 110 x 400 in three pieces 150 + 150 + 100 = 400 mm in length

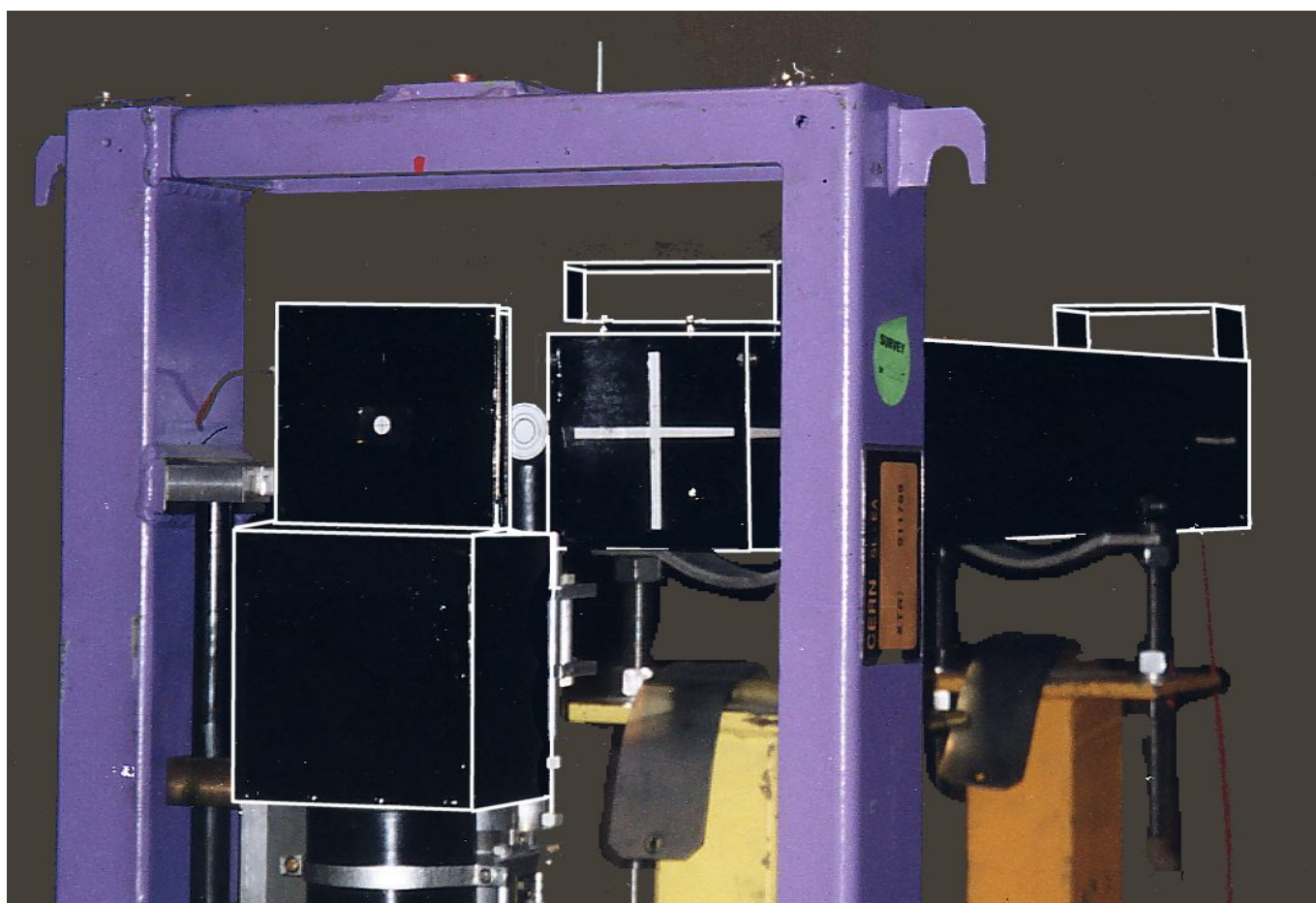
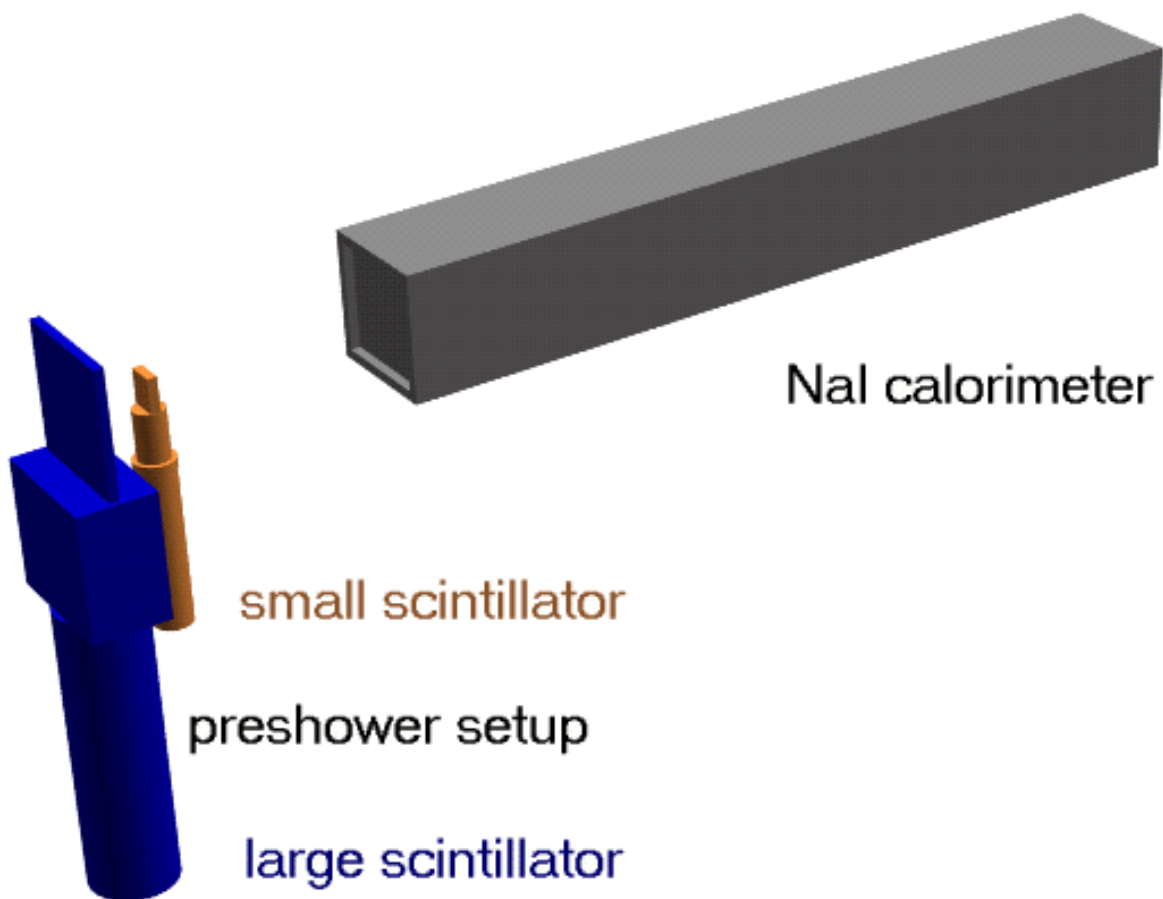

The preshower photon detector, as well as the photon calorimeter was in the charge of the Kharkov KIPT group.