



HAL
open science

The TMR network project Development of γ -ray tracking detectors

R.M. Lieder, W. Gast, H.M. Jager, L. Mihailescu, M. Rossewijn, J. Eberth, G. Pascovici, H.G. Thomas, D. Weisshaar, F.A. Beck, et al.

► **To cite this version:**

R.M. Lieder, W. Gast, H.M. Jager, L. Mihailescu, M. Rossewijn, et al.. The TMR network project Development of γ -ray tracking detectors. Nuclear Physics A, 2001, 682, pp.C279-C285. in2p3-00009929

HAL Id: in2p3-00009929

<https://in2p3.hal.science/in2p3-00009929v1>

Submitted on 21 Jun 2001

HAL is a multi-disciplinary open access archive for the deposit and dissemination of scientific research documents, whether they are published or not. The documents may come from teaching and research institutions in France or abroad, or from public or private research centers.

L'archive ouverte pluridisciplinaire **HAL**, est destinée au dépôt et à la diffusion de documents scientifiques de niveau recherche, publiés ou non, émanant des établissements d'enseignement et de recherche français ou étrangers, des laboratoires publics ou privés.



The TMR network project “Development of γ -ray tracking detectors”

R.M. Lieder^a, W. Gast^a, H.M. Jäger^a, L. Mihailescu^a, M. Rossewij^a, J. Eberth^b, G. Pascovici^b, H.G. Thomas^b, D. Weisshaar^b, F. Beck^c, D. Curien^c, G. Duchêne^c, E. Pachoud^c, I. Piqueras^c, C. Rossi Alvarez^d, D. Bazzacco^d, M. Bellato^d, Th. Kroell^c, Ch. Manea^d, B. Quintana^d, R. Venturelli^d, D.R. Napoli^d, D. Rosso^e, P. Spolaore^e, A. Geraci^f, A. Pullia^f, G. Ripamonti^f, F. Camera^g, B. Million^g, O. Wieland^g, J. Lisle^h, A.G. Smith^h, R. Well^h, P. Nolanⁱ, A. Bostonⁱ, D. Cullenⁱ, M. Descovichⁱ, T. Enqvistⁱ, B. Cederwall^j, E. Ideguchi^j, J. van der Mare^j, J. Nyberg^k, B. Herskind^l, G. Sletten^l, J. Wilson^l, R. Henck^m, D. Gutknecht^m and K. Jääskeläinen^m

^aInstitut für Kernphysik, FZ Jülich, D-52425 Jülich, Germany

^bInstitut für Kernphysik, Universität zu Köln, D-50937 Köln, Germany

^cIReS Strasbourg, F-67037 Strasbourg, France

^dINFN, Laboratori Nazionali di Legnaro, I-35020 Legnaro, Italy

^eINFN, Sezione di Padova, I-35131 Padova, Italy

^fDip. Elettronica e Informazione, Politecnico di Milano, I-20133 Milano, Italy

^gINFN, Sezione di Milano, I-20133 Milano, Italy

^hSchuster Laboratory, University of Manchester, Manchester M13 9PL, UK

ⁱOliver Lodge Laboratory, University of Liverpool, Liverpool L69 3BX, UK

^jDepartment of Physics, KTH Stockholm, S-100 44 Stockholm, Sweden

^kDepartment of Neutron Research, Uppsala University, S-75120 Uppsala, Sweden

^lNiels Bohr Institute, University of Copenhagen, DK-2100 Copenhagen, Denmark

^mEurisys Mesures, F-67834 Tanneries, France

The next generation of 4π arrays for high-precision γ -ray spectroscopy will involve γ -ray tracking detectors. They consist of high-fold segmented Ge detectors and a front-end electronics, based on new digital signal processing techniques, which allows to extract energy, timing and spatial information for a γ -ray by pulse shape analysis of the Ge detector signals. Utilizing the information on the positions of the interaction points and the energies released at each point the tracks of the γ -rays in a Ge shell can be reconstructed in three dimensions.

1. CONCEPT OF 4π γ -RAY TRACKING ARRAYS

The investigation of new phenomena in atomic nuclei requires the study of their structure under extreme conditions at the boundary of stability, where the excitation energy, the spin or the ratio of protons and neutrons (isospin) take extreme values. The most powerful means for such studies is the high-precision γ -ray spectroscopy. Many interesting research topics, especially the investigation of the isospin degree of freedom requires the use of highly efficient and highly granulated γ -detector arrays. The state-of-the-art with respect to 4π γ -detector arrays is represented by EUROBALL in Europe and GAMMASPHERE in the USA consisting partly of composite and two-fold segmented Ge detectors, respectively. A new concept is required to increase the efficiency and granularity of 4π γ -detector arrays. In the present generation of γ -detector arrays about 50% of the total solid angle is covered by BGO anti-Compton detectors. To significantly improve the efficiency, the coverage of the total solid angle with Ge detectors has to be maximized. A Ge shell with an inner radius of 15 cm and a thickness of 9 cm consisting of 120 Ge detectors would for a γ -ray multiplicity of $M_\gamma = 30$ nevertheless only have a total photopeak efficiency of $\epsilon \approx 6.5\%$ similarly to EUROBALL and a peak-to-total ratio of $P/T \approx 13\%$ which is approximately three times smaller than that of EUROBALL. The reason for such a poor performance is the large probability to detect several γ -rays in one detector and the scattering of γ -radiation between the Ge detectors due to the Compton effect. However, if one could follow the tracks of the γ -rays in the Ge shell a dramatic improvement of its characteristics could be obtained resulting in $\epsilon \approx 18\%$ and $P/T \approx 58\%$. In addition, the Doppler shift correction can be significantly improved if the angles at which the γ -rays hit the Ge detectors can be determined with high precision. Such a Ge shell will have a sensitivity which is about two orders of magnitude larger than that of EUROBALL and GAMMASPHERE.

The prerequisite for the construction of such a γ -ray tracking array is the development of γ -ray tracking detectors. They consist of high-fold segmented Ge detectors and front-end electronics based on new digital signal processing techniques, which allows to extract energy, timing and spatial information for a γ -ray by pulse shape analysis of the Ge detector signals. Utilizing the information on the positions of the interaction points and the energies released at each point the tracks of the γ -rays in a Ge shell can be reconstructed in three dimensions on the basis of the Compton scattering formula.

To design γ -ray tracking detectors for a 4π γ -detector array research and technical development is carried out in the following areas: (i) Development of segmented Ge detectors, (ii) Development of digital signal-processing electronics, (iii) Development of pulse shape analysis methods, (iv) Development of tracking algorithms and (v) Simulation of tracking arrays. Important results of the development work are discussed subsequently.

2. DEVELOPMENT OF SEGMENTED Ge DETECTORS

A 4π γ -ray tracking array of large photopeak efficiency and resolving power will be composed of multi-segmented Ge detectors. They will allow to determine the positions at which each γ -ray interacts with the array in three dimensions. The interaction points of the γ -rays in the Ge detector are localized by means of the segmentation of one or both Ge detector contacts and pulse-shape analysis of the segment signals.

A six-fold segmented Ge detector has been successfully developed on the basis of the encapsulated Ge detector of the EUROBALL project [1]. The Ge detector has a semi-hexagonal shape (hexagonal at the front face and circular at the rear side) and is subdivided into six triangular segments if viewed from the front face (azimuthal segmentation) by separation of the outer implanted contact. This detector is encapsulated, a technology which allows to cluster them in various configurations and to investigate and optimize the cabling, grounding and shielding to avoid microphony, cross-talk, shifts and oscillations.

A 25-fold segmented cylindrical Ge detector which has six azimuthal and four longitudinal segments plus one central circular segment at the front has been developed. It has 25 cold field-effect transistors, one for each segment all placed in the Ge crystal vacuum chamber. The energy resolutions of the segments are on average 2.2 keV. No cross talk has been observed in the preamplifier signals.

Development work on a stack of segmented planar Ge detectors has been started. Technical improvements, like the reduction of the dead layer on the passivated surface or the use of an implanted phosphorous contact, would greatly increase the interest in such a detector.

3. DEVELOPMENT OF DIGITAL SIGNAL-PROCESSING ELECTRONICS

The task of the pulse processing system is to digitize the preamplifier signal using an analog-to-digital converter (ADC) with sufficient resolution and sampling rate and to provide digital signal processing hardware powerful enough for on-line processing of the signals. The high dynamic range as well as the bandwidth of the preamplifiers of around 20 MHz implies the necessity to sample the preamplifier output signal with at least 12 bit and 40 Msps/s in order to allow for the desired digital signal processing and pulse shape analysis. A γ -ray tracking array consisting of about 100 Ge detectors, which are 20-30 fold segmented, will have up to 3000 processing channels producing each a primary data rate of 60 Mbyte/s. This requires a compact digital signal processing electronics with high computing power for on-line data reduction. In the ideal case the whole information should be reduced to only five values per interaction: E_γ , t_γ and the three coordinates of the interaction point.

A new version of the Pulse-Processing ADC (PPADC) [2] in which up to eight digital processing channels can be integrated as daughter boards on one mother board has been built in cooperation with the company “target system electronics GmbH” Solingen, Germany. The mother board makes the communication with the host PC. Two daughter board versions exist, a 20 MHz version with a 12 bit 20 MHz ADC and two digital signal processors (DSP), and a 80 MHz version with two 12 bit 40 MHz ADCs, one programmable logic device (PLD) and one DSP, which has been specifically designed to allow pulse-shape analysis. Software for control, testing, and readout of the PPADC has been written.

Depending on the information which has to be extracted from the Ge detector pulses, different optimized signal processing algorithms exist or have to be developed and applied. The time invariant Moving Window Deconvolution (MWD) for instance has been proven to be an optimal filter, if information about the released total energy E_γ has to be ex-

tracted [3]. For timing and pulse shape algorithms only the leading edge of the signals, i.e. a small part of the data stream is relevant. For lifetime measurements and the extraction of the position information, a timing with a resolution of sub sampling interval accuracy is needed. Therefore a new, digital timing discriminator has been designed, the algorithm of which is simple and compact enough to run on-line on the PPADC hardware. The concept is based on the idea, that the original detector signals are steplike in the very beginning. This means, that for a given preamplifier response function a very well defined relation exists between the starting point of the signal and the amplitudes of the first few samples measured. An algorithm based on this idea has been developed and implemented on the PPADC giving a time resolution of 8 ns for a large-volume Ge detector measured in coincidence with a plastic scintillator for a ^{60}Co source taking a large dynamic range.

4. DEVELOPMENT OF PULSE SHAPE ANALYSIS METHODS

The pulse shapes produced by γ -rays interacting with a Ge detector contain information about the three-dimensional position of each individual interaction within the detector volume and the energy released at each interaction. The tracking efficiency, and hence the final performance of a complete tracking array, depends on the precision of these data. The analysis should preferably be done on-line, to keep the data rate at a level which can be handled by present data acquisition systems. That is, the algorithms have to be converted into efficient real-time code, which has to be implemented on dedicated, high performance digital signal processing electronics.

The charge collection process, i.e. the carrier drift in Ge crystals at high electric fields and low temperature has been experimentally and theoretically studied and an anisotropy of the drift velocity depending on the crystal orientation, as well as an orientation-dependent angular shift of the drift direction have been found [4]. For the first time it was demonstrated, that this anisotropic drift of the carriers must be taken into consideration if γ -ray tracking is concerned. The experimental investigations have been carried out with a semi-hexagonal Ge detector of the EUROBALL project. The detector was scanned with collimated ^{22}Na and ^{241}Am sources. The detector signals were recorded with a digital oscilloscope and the differentiated charge signals were subsequently analyzed. In fig. 1 the time between the beginning of the pulse and when it reaches its maximum (time-to-maximum) is plotted in a polar diagram for a few radii as function of angle [4]. The measurements were taken in the front and coaxial regions of the Ge detector. A variation of the charge collection time of up to 35% is obtained for different drift directions relative to the crystal orientation. The results are in good agreement with simulations and the charge collection process is considered to be well understood now.

Methods for the determination of the interaction positions of γ -rays in segmented Ge detectors have been developed. They take into account the shapes of the induced “real” and “mirror” charge signals. Real charge signals are measured at the electrodes of the segment, in which an interaction takes place. Mirror-charge signals are measured on the electrodes of the neighbouring segments, where no interaction takes place and are due to a capacitive coupling between these segments and the moving charges. Simulated signals for real and mirror charges of a 25-fold segmented detector were used as input to an artificial neural network and a genetic algorithm to study their ability to distinguish

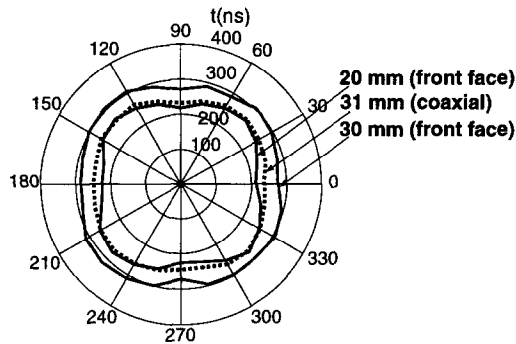

Figure 1. Polar plot of the time-to-maximum for pulses from 60 keV γ -rays emitted from a ^{241}Am source measured with a Ge detector. The angles of 0° and 90° correspond to its $\langle 100 \rangle$ and $\langle 010 \rangle$ crystallographic directions, respectively. Reprinted from Nucl. Instr. and Meth. A447, L. Mihailescu, W. Gast, R.M. Lieder, H. Brands and H. Jäger, The influence of anisotropic electron drift velocity on the signal shapes of closed-end HPGe detectors, p. 350 – 360, © 2000, with permission from Elsevier Science.

between single and multiple interactions and to extract the position and energy information. A correct identification of the number of interactions was obtained for the latter at a success rate of more than 90% with a position resolution of better than 2 mm and an energy resolution of better than 4% for two events. Furthermore, a pattern recognition system based on the wavelet transform of simulated charge signals was investigated. The coefficients of a “wide-band” (WB4) orthogonal transformation of the signals were compared to data bases with WB4 coefficients of signal shape types (pattern classes) to identify the best fit via a first nearest neighbour algorithm and a calculation of the membership function of the identified class. It was found, that a localisation of the interaction region in a segment with a position resolution of the order of 1 mm^3 may be achieved for single events, if correlations with mirror charge signals are utilized in the analysis.

5. DEVELOPMENT OF TRACKING ALGORITHMS

Extensive simulations of the interaction of γ -radiation with Ge detectors have been performed using the Monte Carlo code GEANT. The simulations have been carried out for a certain detector geometry and a standard set of γ -ray energies and γ -multiplicities. A result which is significant for the detector development and pulse shape analysis is that for a typical Ge detector of 80% relative efficiency with about 30 segments, the detection of a 1.33 MeV γ -ray produces in 50% of the cases more than one interaction point in the same segment. Concerning the energy distribution of the individual interactions of a γ -ray in a Ge detector it has been found that, rather independently of the initial γ -ray energy, most of the spectral intensity for photoelectric absorption lies somewhat above $E_\gamma \approx 100 \text{ keV}$ whereas the Compton scattering spectrum is peaked at a lower energy.

The successful development of two alternative algorithms for γ -ray tracking has shown

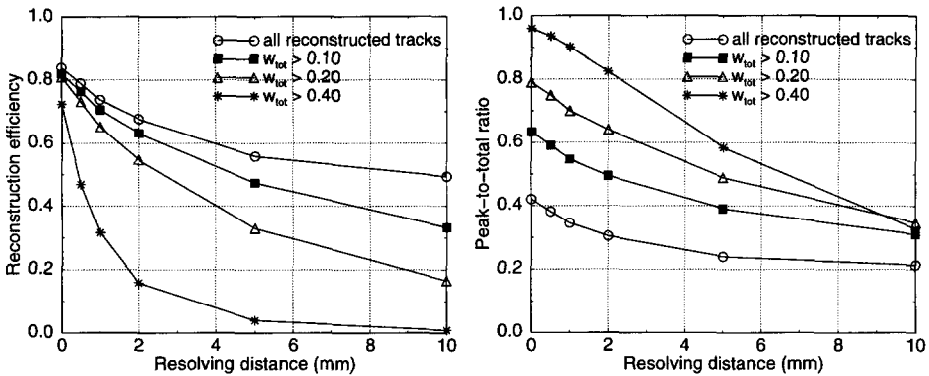

Figure 2. The dependence of the peak-to-total ratio and the reconstruction efficiency for a full-energy peak of 1.33 MeV on the resolving distance for various thresholds of the figure of merit w_{tot} . Reprinted from Nucl. Instr. and Meth. A437, J. van der Marel and B. Cederwall, Backtracking as a way to reconstruct Compton scattered γ -rays, p. 538 – 551, © 1999, with permission from Elsevier Science.

that it is a viable solution for the development of a new generation of 4π γ -ray arrays. (i) In one method a two-step procedure is applied. At first clusters of interaction points are identified which likely represent the path of one γ -ray [5]. Subsequently for each cluster, a test of all permutations of the coordinates and energy depositions of the interaction points against the Compton scattering formula is carried out in order to distinguish the acceptable sequences from those that, because of incomplete absorption of the γ -ray, must be rejected. (ii) The other approach starts from points likely to be the last of the interaction sequence because they are associated with an energy deposition in the range of 100–300 keV and traces the tracks back, step by step using the Compton scattering formula and the cross sections for photo and Compton effects, to the origin of the γ -ray without assuming a preliminary clusterisation. This method is called “backtracking” [6] and allows, in principle, to disentangle the interaction points of two γ -rays which enter the detector at a very close distance. For cascades of 25 γ -rays and for an idealized spherical shell geometry, both tracking algorithms give presently a reconstruction efficiency of 30 to 70% for $E_\gamma = 1.33$ MeV, depending on the assumed accuracy to which the coordinates of the interaction points can be determined. The performance of the first tracking algorithm depends mainly on the correct identification of the clusters while the backtracking is limited by the position resolution of the interaction points. In fig. 2 the dependence of the reconstruction efficiency and peak-to-total ratio on the resolving distance is shown for various thresholds of the figure of merit w_{tot} , which is the probability that a track is correctly identified [6]. For a sharpening of the selection criterion, i.e., for an increase of the threshold of w_{tot} , the peak-to-total ratio increases but the reconstruction efficiency decreases. However, the general trend is that the peak-to-total ratio and reconstruction efficiency increase with decreasing resolving distance emphasizing that the position

resolution should be optimized.

It can be concluded, that the basic principles of γ -ray tracking have been successfully developed and that a γ -ray tracking array with superior features can be built. Nevertheless, a large amount of detailed technical development is still required.

This investigation is supported financially by the EU, under the TMR Network Project contract ERBFMRXCT970123.

REFERENCES

1. J. Eberth et al., Nucl. Instr. and Meth. A369 (1996) 135
2. W. Gast et al., to be published in IEEE Trans. Nucl. Sci. (2000)
3. A. Georgiev, W. Gast, and R.M. Lieder, IEEE Trans. Nucl. Sci., 41 (1994) 1116
4. L. Mihailescu et al., Nucl. Instr. and Meth. A447 (2000) 350
5. G.J. Schmid et al., Nucl. Instr. and Meth. A430 (1999) 69
6. J. van der Marel and B. Cederwall, Nucl. Instr. and Meth. 437 (1999) 538